

# 使用说明书

## Operate Manual

---

# 目录 CATALOGUE

---

[一]使用须知	01	7.8 我的色彩	54
[二]注意事项	02	7.9 个人中心	62
[三]功能描述	03	7.10 关于	63
[四]技术参数	04	7.11 日志	64
[五]外观结构介绍	06	7.12 更新	65
[六]测量流程图	09	[八]测量界面介绍	66
[七]软件界面介绍	11	8.1 色差	66
7.1 功能介绍	11	8.2 数据	72
7.2 登陆	13	8.3 图形	73
7.3 向导	16	8.4 雾度	80
7.4 校准	23	8.5 遮盖力	82
7.5 测量	29	8.6 同色异谱	84
7.6 设置	31	8.7 液体色度	85
7.7 数据浏览	49	8.8 相近色查找	86
		8.8 色母粒	88
		8.8 钛白粉	89
		8.8 糊状物	90
		[九]异常处理分析	91
		[十]附件	92
		[十一]公司声明	95

# 使用须知

- 1、本机主要用于测量样品的光谱数据、光谱图、色度值、色差值、呈现合格/不合格、色彩仿真示意图等。结构紧凑轻便测试高度精准、操作简易。
- 2、广泛应用于实验室、工厂、或现场操作，足以在几乎所有应用领域的质量控制中实现最佳的色彩测量。
- 3、限制性保修的时间段是自购买本仪器开始起（时间：如一年）的时间。如果您的仪器需要服务，请将仪器带到当地的销售部联系我们来进行维修。
- 4、为了避免仪器精度受影响，请不要将仪器私自拆开。如果由于私自拆卸机器或不正确的使用而导致仪器损坏，请用户自行负责。

# 注意事项

- 1、本机属精密仪器，不能承受跌落导致的碰撞，使用时请放置于相对平整的地方。
- 2、本机不能防潮或抗潮，受潮或液体溅入易损坏本机。
- 3、本机的屏幕是由玻璃制成，受到异常外力或锐器的作用易损坏。
- 4、本公司建议使用原配电源适配器。
- 5、为保障本机正常工作，请不要在过冷或过热的地方存贮和使用，也勿将本机放置在潮湿或阳光长期直射的地方，更不要在强震等恶劣的环境中使用本机，以免发生意外。
- 6、本机是精密仪器，使用时请避开强电磁干扰。
- 7、为保证测量准确，测试时请保持仪器平稳，不要摇晃。
- 8、本机属精密仪器，使用完毕请将仪器关机保管。
- 9、请将仪器存放在干燥的地方。
- 10、禁止对积分球内部进行清洁。
- 11、如果仪器发生故障，请不要尝试自行修理，我们的客户服务部门会快速的为客户提供帮助。

12、本机及说明书如有进一步改进或补充，恕不另行通知。如有疑问，敬请垂询本公司。

## 功能描述

- 1、符合标准：CIE No.15、GB/T 3978、GB 2893、GB/T 18833、ISO7724/1、DIN 5033 Teil7、JIS Z8722 条件C、ASTM E1164;透射：d/0（漫射照明，垂直方向接收）
- 2、既能对非透明物体进行反射测量，又能对透明物体进行透射测量;
- 3、可测量SCI（包含镜面反射）/SCE（不包含镜面反射）；
- 4、采用脉冲氙灯，提供宽光谱照明光源;
- 5、拥有开放式的测量区域，可以满足任意大小的样品测量;
- 6、采用7.0寸电容触摸屏，拥有良好的人机交互界面；
- 7、U盘导出数据，可在PC端查看管理；
- 8、内置多个测量模块，能满足绝大部分客户需求;
- 9、提供专业的颜色测量分析软件，可以满足用户对测试数据的分析以及管理。

# 技术参数

照明/受光系统	反射: d/8 (漫射照明, 8° 方向接收) SCI (包含镜面反射光) / SCE (不包含镜面反射光) 同时测量。符合标准: CIE No.15、GB/T 3978、GB 2893、GB/T 18833、ISO7724/1、DIN5033 Teil7、 JIS Z8722 条件C、ASTM E1164、ASTM-D1003-07 透射: d/0 (漫射照明, 垂直方向接收)
传感器	双列高精度CMOS阵列传感器
分光方式	凹面光栅
积分球直径	152mm
测量波长范围	360-780nm
测量波长间隔	10nm
光波宽	1nm
反射率测量范围	0-200%, 分辨率0.01%
照明光源	脉冲氙灯和LED
紫外测量	包含UV、400nm截止、420nm截止、460nm截止
测量时间	SCI或SCE模式<2秒, SCI+SCE同时测量<4秒
测量/照明口径	反射:XLAV Φ25.4mm/Φ30mm,LAVΦ15mm/Φ18mm,MAVΦ8mm/Φ11mm, SAVΦ3mm/Φ6mm 用户可自定义口径,口径切换自动识别 透射:Φ17mm/Φ25mm
透射测量规格	样品宽度与高度无限制,厚度:≤50mm
长期重复性	XLAV色度值:标准偏差 ΔE*ab 0.015以内 (20°C ± 10°C任意温度变化,24小时内每小时测量一次白色校正板)
重复性	ΔE*ab≤0.01; 光谱反射/透过率:≤0.1% (仪器校正后,以5秒间隔测量白色校正板30次以XLAV口径测量结果标准偏差)
器间差	XLAV ΔE*ab 0.2 (基于23°C时,测量 BCRA Series系列12色板平均值)

标准观察者	2° 标准观察者和10° 标准观察者
测量光源	A,C,D50,D55,D65,D75,F1,F2,F3,F4,F5,F6,F7,F8,F9,F10,F11,F12,CWF,U30,DLF,NBF,TL83,TL84
语言	中文简体、英文、中文繁体、俄语、西班牙语、葡萄牙语、日语、泰语、韩语、德语、法语、波兰语
显示内容	光谱数据,光谱图,色度数据,色差数据,色差图,合格/不合格判断,仿真色彩,色彩评估,雾度,液体色度,颜色偏向
颜色空间	L*a*b, L*C*h, Hunter Lab, Yxy, XYZ
色度指标	WI(ASTM E313-00,ASTM E313-73,CIE/ISO,AATCC,Hunter,Taube,Berger Stensby), YI(ASTM D1925,ASTM E313-00,ASTM E313-73),Tint(ASTM E313-00),同色异谱指数Milm,沾色牢度,变色牢度,ISO亮度,R457,A密度,T密度,E密度,M密度,APHA,Hazen,Pt-Co (铂钴指数),Gardner (加德纳指数),Saybolt(塞伯特指数),Astm color,雾度,总透过率,遮盖力、力份、强度
色差公式	$\Delta E^*ab$ , $\Delta E^*CH$ , $\Delta E^*uv$ , $\Delta E^*cmc$ , $\Delta E^*94$ , $\Delta E^*00$ , $\Delta Eab$ (Hunter),555色调分类
存储空间	8GB
屏幕尺寸	10寸电容触摸屏
操作系统	Andriod
电源	直流稳压电源
操作温湿度范围	5 ~ 40° C, 相对湿度80%(35° C 时)以下无凝露
储存温湿度范围	-20 ~ 45° C, 相对湿度80%(35° C 时)以下无凝露
附件	电源适配器、数据线、透射夹具、U盘、黑腔、白板、绿板、0%校准遮光盖、30mm□径板、18mm□径板、11 mm□径板、6 mm□径板、支撑台、阻尼把手、比色皿
可选附件	加热透射夹具、立式支架、气动顶杆、小样品夹持配件、反射比色皿支架、耐腐蚀防护板、纤维测试盒、薄膜夹具、微量透射夹具、拉杆箱、欧标插头、美标插头
接口	RS-232、USB、USB-B

其他	<ol style="list-style-type: none"><li>1.摄像头取景定位</li><li>2.仪器可侧面测量,朝上测量,朝下测量(使用配件)</li><li>3.自动温湿度补偿功能</li></ol>
----	---

## 外观结构介绍

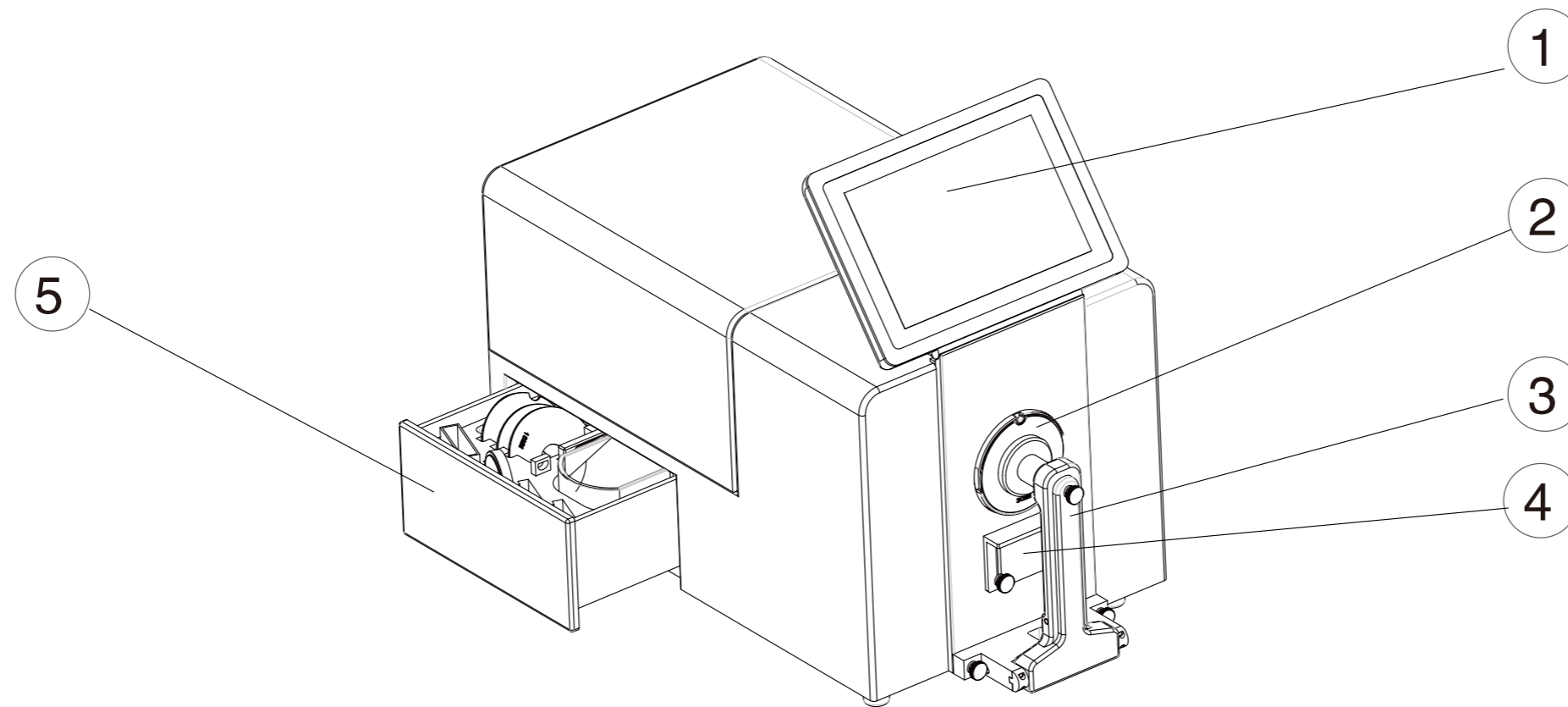

① 触摸屏

② 测试口径

③ 把手

④ 支撑台

⑤ 抽屉

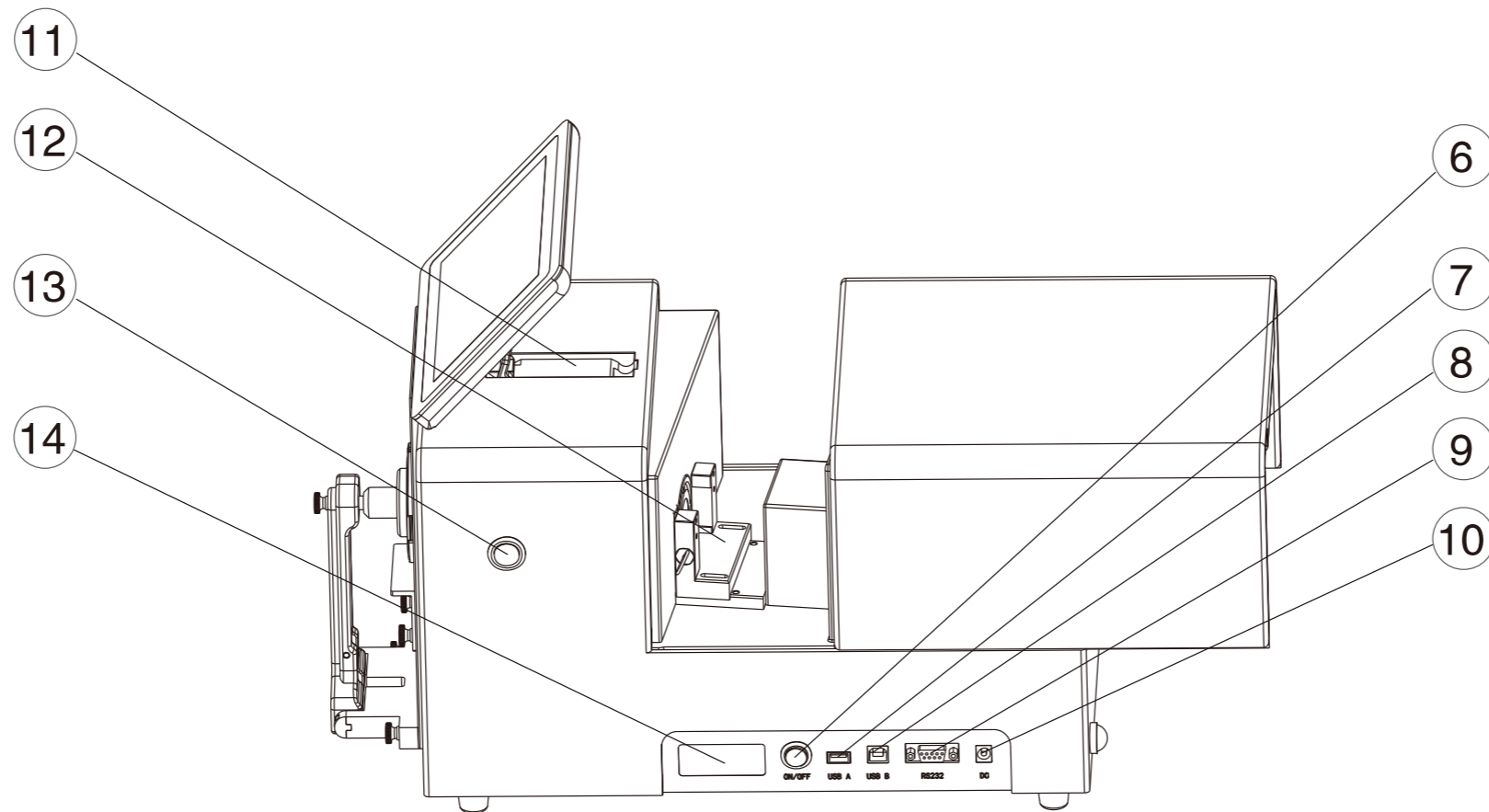

⑥ 电源开关

⑦ USB口

⑧ USB-B口

⑨ 串口

⑩ DC电源插座

⑪ 屏幕防抖支架

⑫ 透射测试夹具

⑬ 测试按键

⑭ 铭牌

⑮ 滑盖锁扣

⑯ 手动阻尼顶杆

⑰ 台架

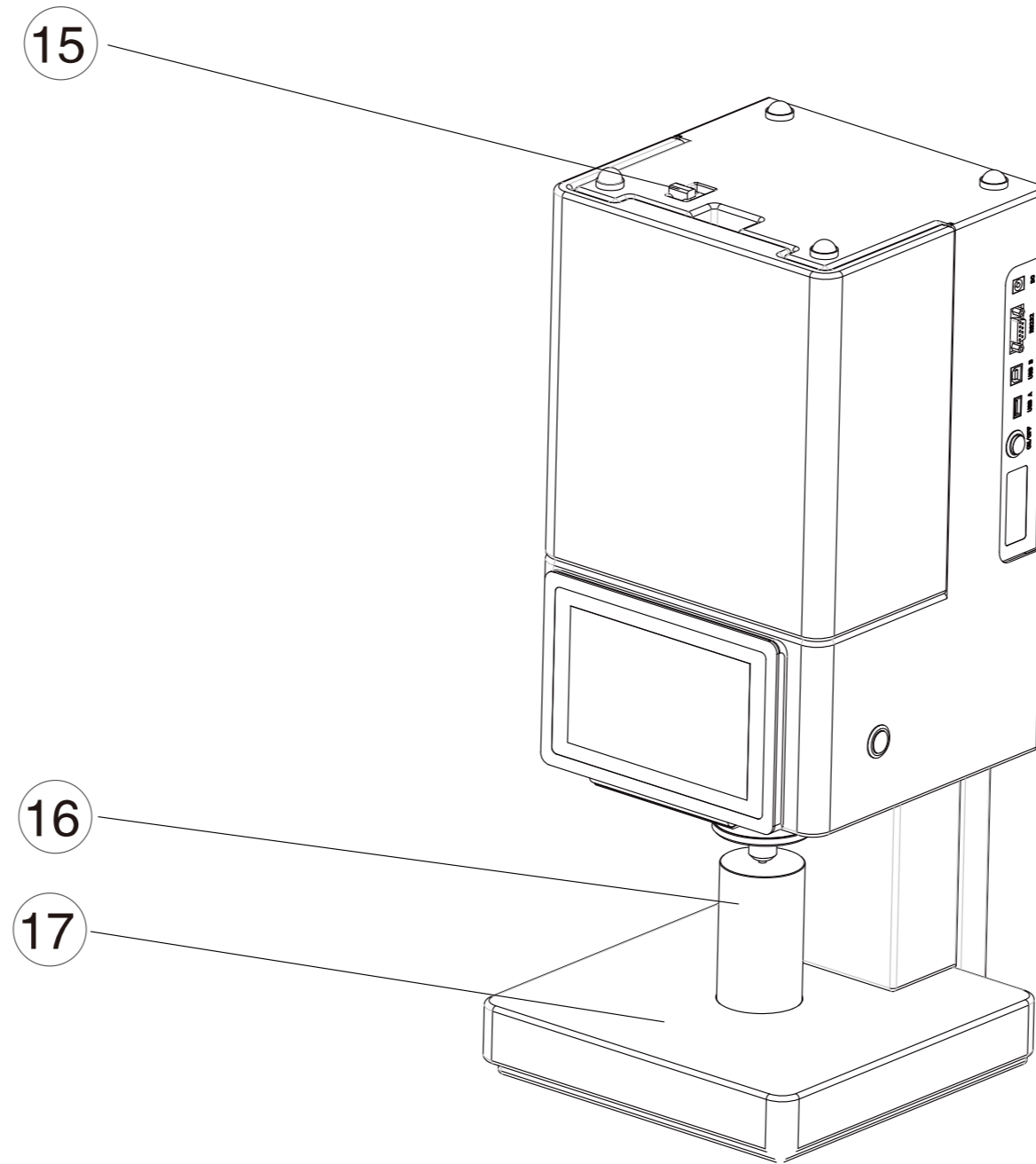

# 测量流程图

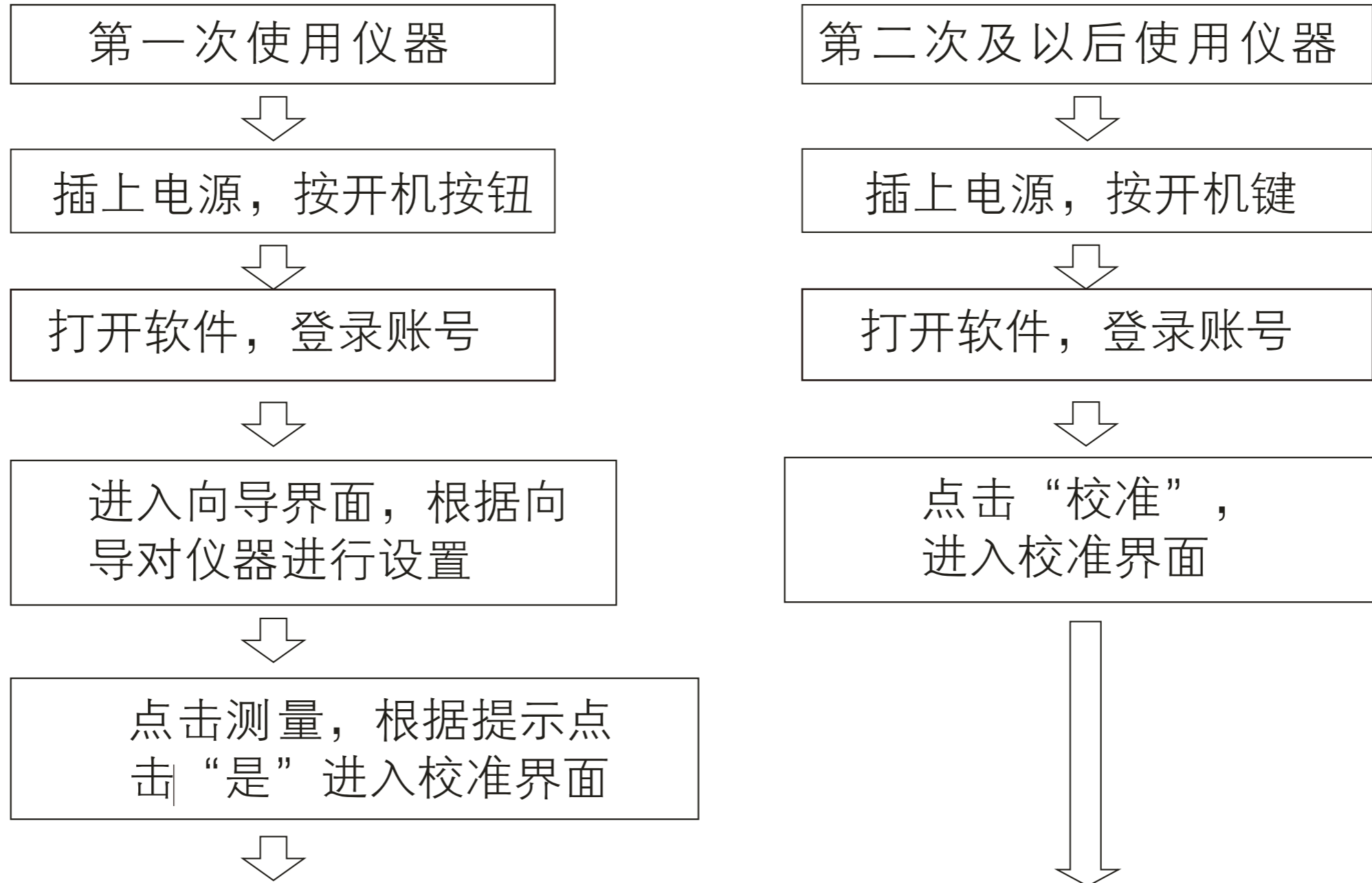

黑校准、白校准、绿校准



标样测量、试样测量



检查测量结果

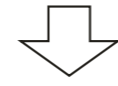

保存、不保存测量结果



完成

# 软件界面介绍

## [功能介绍]

### A-1

#### 主界面

软件分为9个模块，分别是：测量、设置、数据浏览、我的色彩、个人中心、关于、日志、更新、校准。



A-2

标题栏



## [登录]

登录分为本地登录和网络登录两种方式，输入账号和密码，仪器会自动识别账户类型。勾选记住密码，下次开机时将会自动输入账户与密码，勾选自动登录下次开机将跳过登录页面，直接进入软件。

# B-1

本地登录账户为：admin，密码默认为仪器序列号（登录后可以在个人中心进行修改）。  
例如仪器序列号是：C81118C0128，则在登录密码处输入C81118C0128即可。

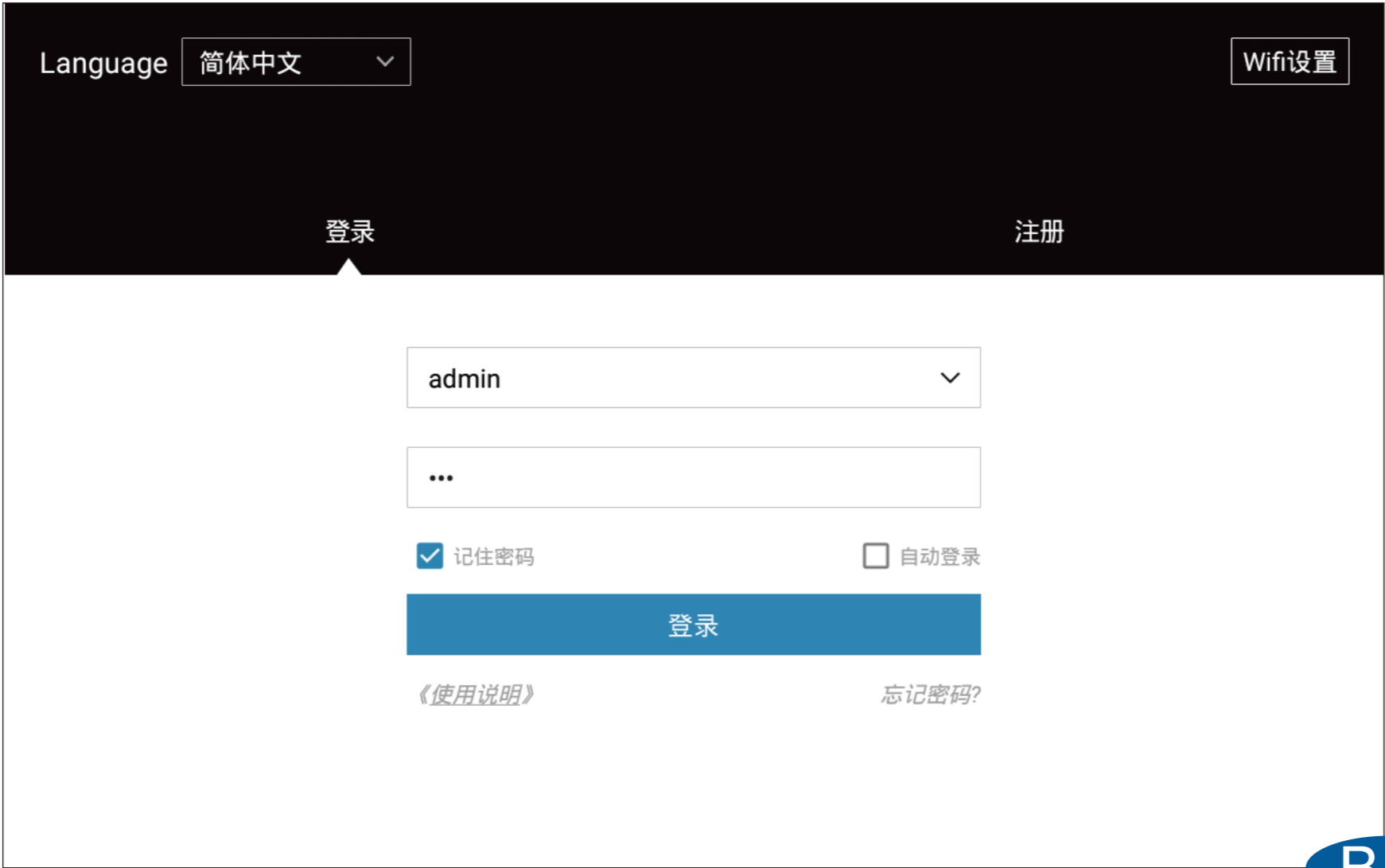

# B-1

## B-2

### 网络登录

网络登录需要连接网络，点击注册进行账户注册，可选择邮箱或手机号进行注册。注册完成后可以使用注册的账户进行登录。使用网络登录可以将存储的数据上传到云端，可在windows端进行数据管理。

The screenshot shows a web interface for login and registration. At the top left, there is a language selector set to '简体中文' (Simplified Chinese) and a 'Wifi设置' (Wifi Settings) button. Below this, there are two tabs: '登录' (Login) and '注册' (Register), with the '注册' tab currently selected. The registration form consists of several input fields: '请输入账号' (Please enter account), '请输入公司名称' (Please enter company name), '请输入密码' (Please enter password), '请输入公司地址' (Please enter company address), '请确定密码' (Please confirm password), '请输入联系人姓名' (Please enter contact name), '请输入手机号码或邮箱' (Please enter mobile number or email), '请输入验证码' (Please enter verification code), and '获取验证码' (Get verification code). A large blue '注册' (Register) button is positioned at the bottom right of the form area.

B-2

# [向导]

## C

第一次登录软件或恢复出厂后重新登录后，会进入仪器使用向导，可以根据向导对仪器进行设置。



C-1

## 模式选择

取消

完成



反射模式



透射模式

1/6

上一步

下一步

C-2

## 仪器设置

取消

完成

### 测试模式

SCI

SCE

SCI+SCE

### UV设置

UV400截止

UV420截止

UV460截止

包含UV

### 口径设置

自动识别

自定义

4-30

mm

忽略口径错误(软件将不提示口径错误)

2/6

上一步

下一步

C-3

## 参数设置

### 光源&视角 (第二光源用于计算同色异谱)

第一光源

D65

10°

第二光源

A

2°

### CMC(l:c)

l 2.0

c 1.0

### CIE94

KL 1.0

KC 1.0

KH 1.0

### CIE 2000

KL 1.0

KC 1.0

KH 1.0

3/6

上一步

下一步

C-4

# 容差设置

取消

完成

CIE LAB&LCH Hunter Lab CIEDE2000 CIE LUV CMC(l:c)&CIE94 液体色度 雾度 温度&湿度 参数自适应

## CIE LAB

		大于正值	小于负值	两者之间
dL*	± 2.0	白多黑少	黑多白少	合格
da*	± 2.0	红多绿少	绿多红少	合格
db*	± 2.0	黄多蓝少	蓝多黄少	合格
dE*ab	2.0	不合格		合格

## CIE LCH

dC*	2.0	dH*	2.0
-----	-----	-----	-----

4/6

上一步

下一步

C-5

## 其他设置

取消

完成

### 平均设置

单次测量       平均测量

### 保存设置

手动保存       自动保存

### 命名规则

标样            +  序号      +       日期

试样            +  序号      +       日期

### 加热模具设置

启用加热夹具

目标温度:

当前温度: 0.00°C

5/6

上一步

下一步

C-6

# 模板选择

取消

色差

数据

图形

雾度(透射)

遮盖力

同色异谱

液体色度(透射)

相近色查找

色母粒

CIELABCH

CIEDE2000

CIE94

CMC

Hunter Lab

标样	试样	差异值	状态
L* = 98.74	L* = 98.74	dL* = 0.01	合格
a* = -0.04	a* = -0.03	da* = 0.01	合格
b* = 0.43	b* = 0.42	db* = -0.00	合格
c* = 0.43	c* = 0.42	dc* = -0.00	合格
h = 95.08	h = 94.00	dH* = -0.01	合格
		dE*ab	0.01 合格

上一步

完成

6/6

C-7

# [校准]

## D-1

### 黑白校准

仪器设置为反射测量模式时，需要进行黑校准与白校准，根据软件的提示进行黑白校准。该页面可以对校准有效期进行设置，可以设置校准有效时间、校准有效温度，校准有效湿度。





校准

D65/10° SCI /

反射

UV400截止

Φ 30

21.9°C

23.8%RH

校准有效时间

8小时

校准有效温度

±10°C

校准有效湿度

±15%RH



第二步

白校准

反射测量口放入白板

点击校准

校准

上一步

跳过

退出

D-1/2

## 绿校验

黑校准与白校准完成后，软件会提示进行绿校验；

绿校验是用来检验仪器数据是否准确。可以选择跳过不进行绿校验。

仪器出厂软件自带的绿板数据，用户也可以在绿板设置里面对绿板进行设置。

注：绿校准需要在UV400截至模式下进行。





# [测量]

测量分为三种模式：标样测量、试样测量以及其他测量模式（遮盖力、相近色查找）。

**E-1**

## 标样测量

在主页点击测量进入标样测量界面，在样品放置完成后，点击屏幕右下角测量按钮，或仪器侧面的测试键，屏幕上显示测量数据，测量按钮恢复可按压状态，表示测量完成。

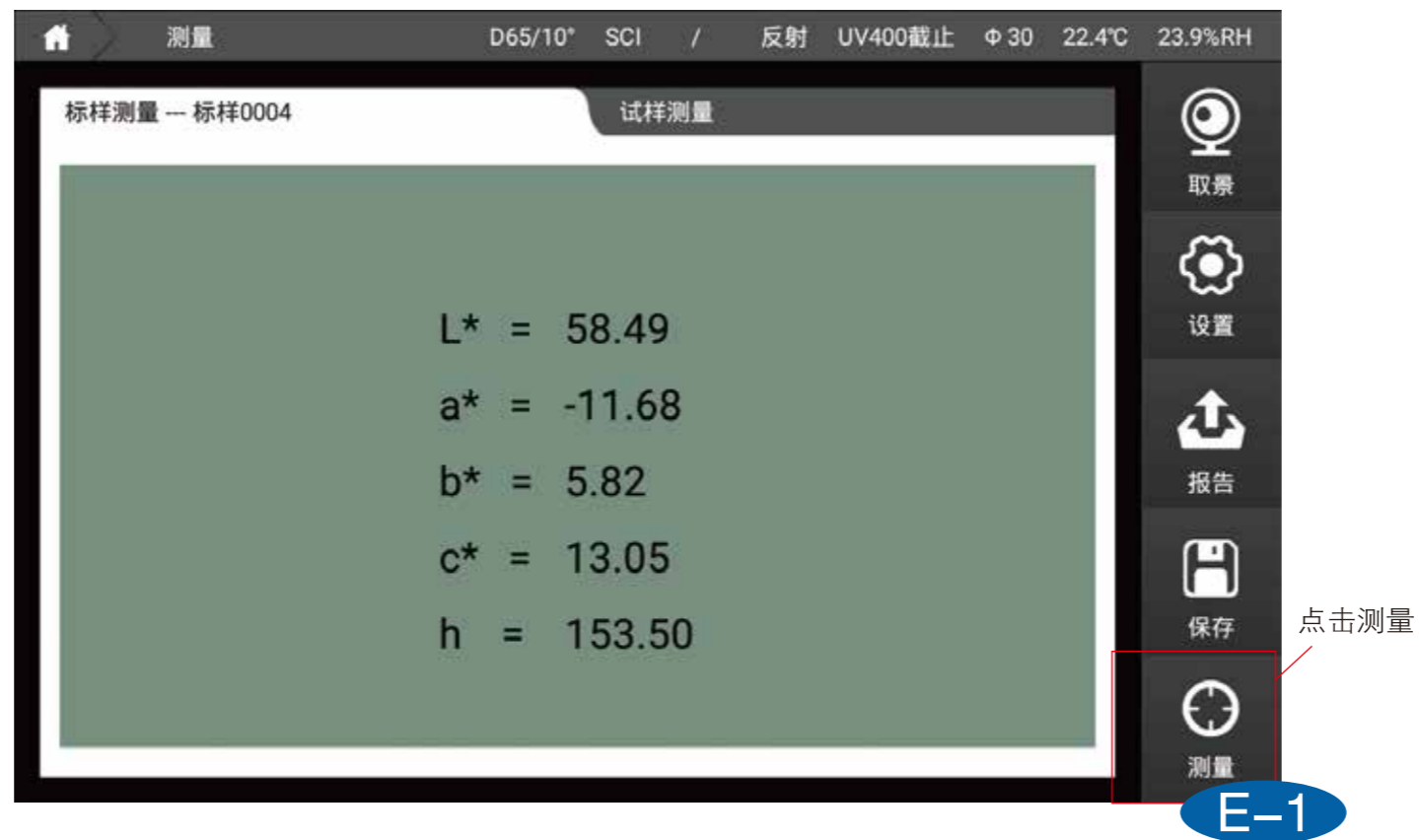

# E-2

## 试样测量

在标样测量界面，点击界面上的试样测量，切换到试样测量界面，同样在样品放置完成后，点击屏幕右下角测量按钮，或仪器侧面的测试键，进行试样数据测量。

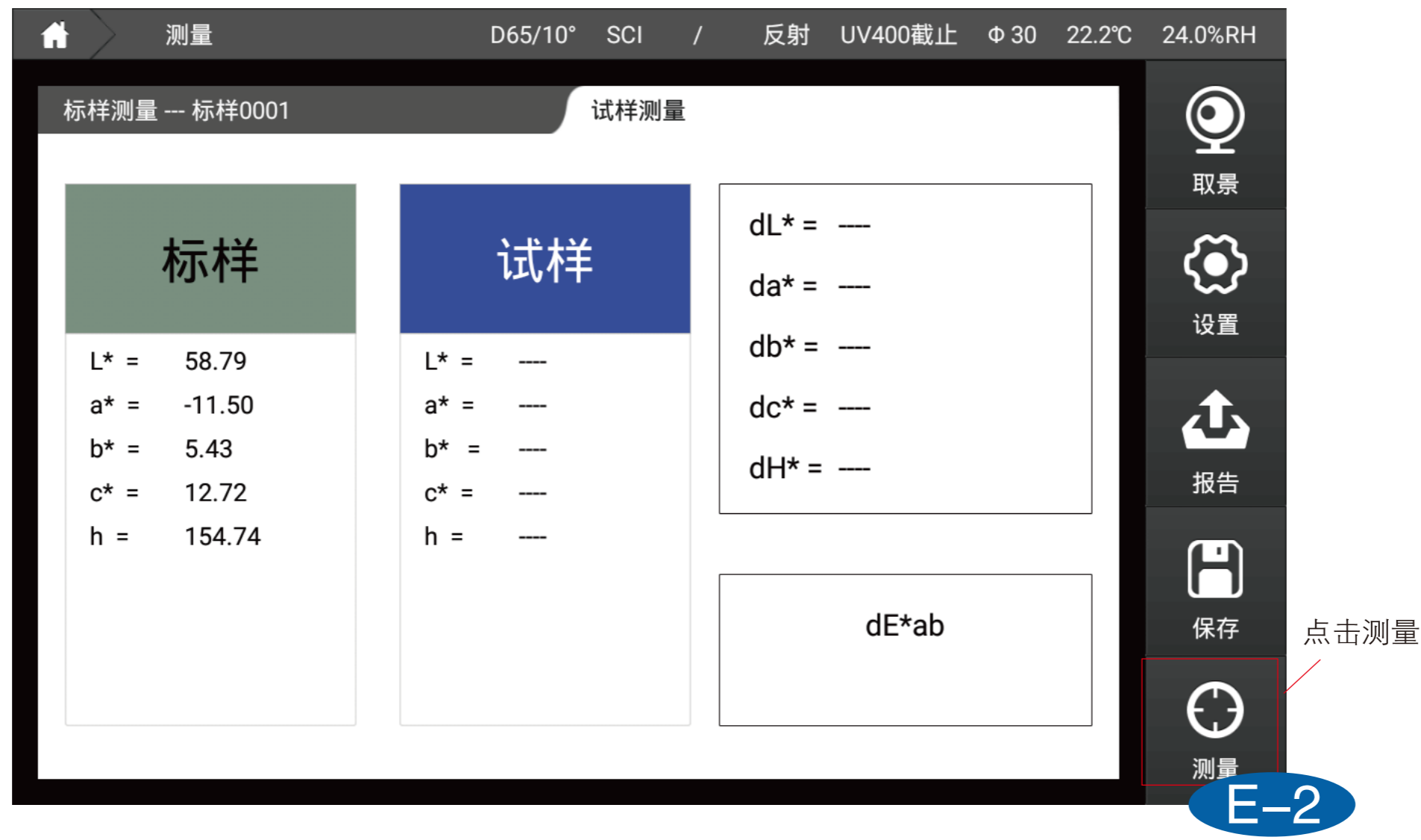

# [设置]

设置界面可以对仪器测量方式、数据计算参数、容差、软件显示、保存方式、命名规则、平均等进行配置，进行修改后需要点击“应用”按钮。

## F-1

### 仪器设置

- 1、透射反射窗口下，选择反射或者透射，用于设置仪器的工作模式。
- 2、测试模式窗口下，选择SCI或者SCE或者SCI+SCE，用于设置仪器的测试模式。
- 3、UV设置窗口下，可以设置包含UV或者UV400截止、UV420截止、UV460截止。
- 4、口径设置窗口下，如果选择自动识别，这个时候就可以自动识别出厂配置的口径，自动切换透镜位置；如果选择自定义，然后在自定义窗口输入4到30以内的数值，同时选择忽略口径错误，就能使用自带的口径测量。

荧光校准,可手动导入或从EXCEL导入LAB、白度、光谱等类型的数据,进行荧光校准。

(1) 点击荧光校准,检查并确认弹出的提示后,选择确定已进行荧光校准。



(2) 进入荧光校准界面, 请按提示进行一次黑白校准, 绿校准可跳过。



(3) 点击设置后会请求admin密码。默认为仪器的序列号(区分大小写)。



(4) 正确输入admin密码后可进行荧光校准设置。可手动导入或者从EXCEL导入。

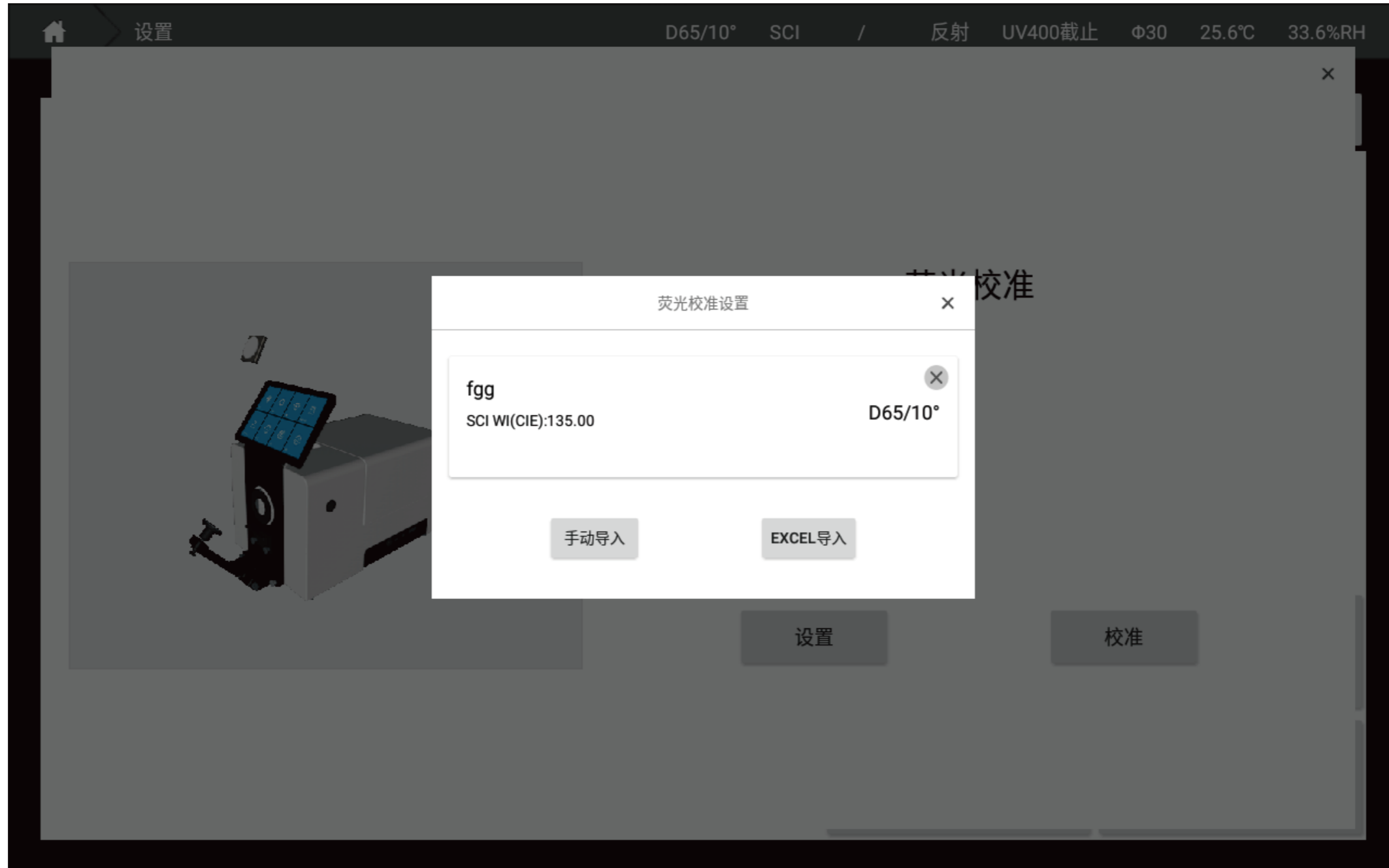

(5) 点击手动导入, 自动询问导入的数据类型。



(6) Lab导入。可自定义此次导入数据的名称。选中SCI或SCE后可以输入对应模式的L\*、a\*、b\*值。

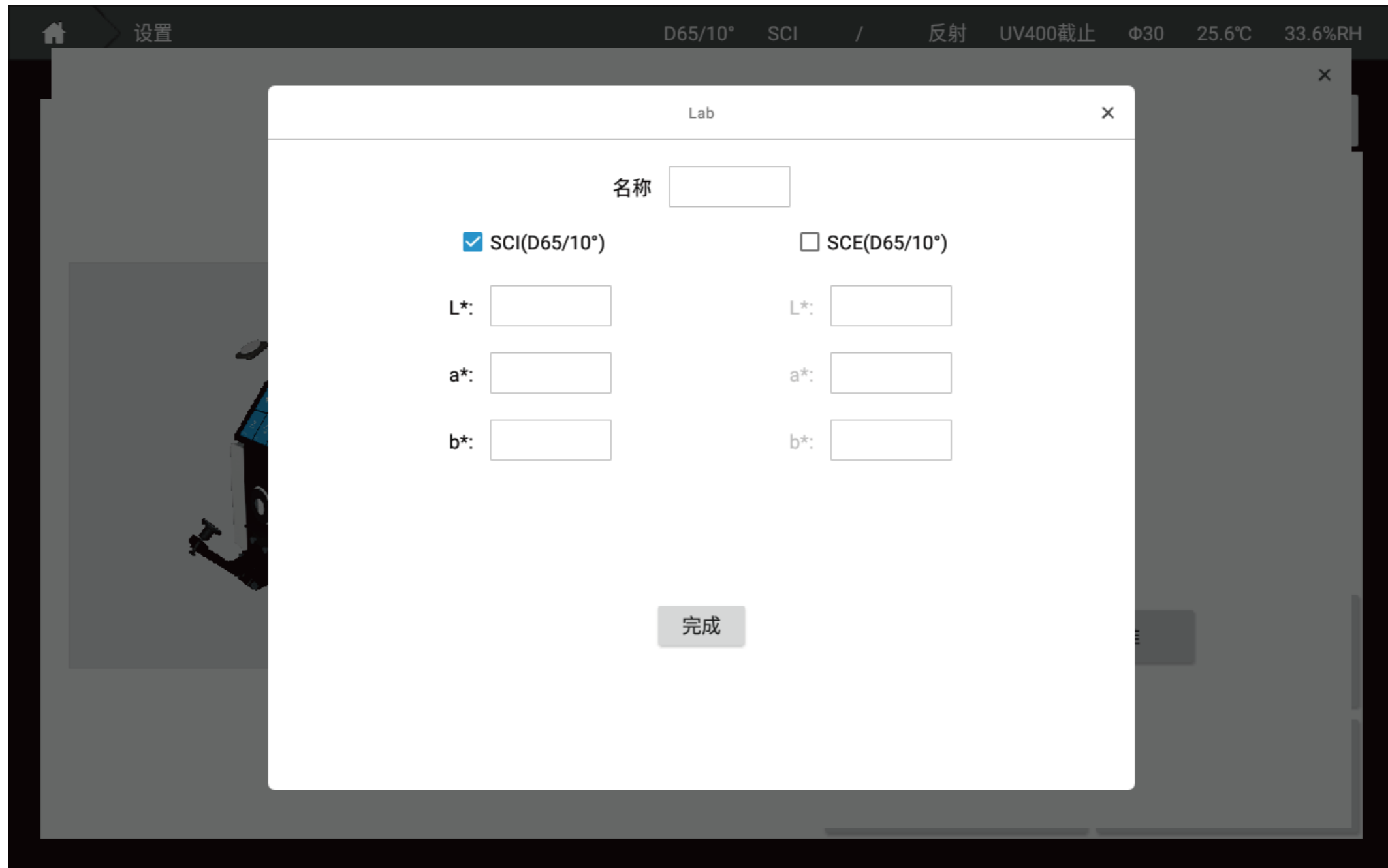

(7) 白度导入。可自定义此次导入数据的名称。选择导入的白度类型(CIE、Hunter等)。选中SCI或SCE后可以输入对应模式的白度值。



(8) 光谱导入。可自定义此次导入数据的名称。选中SCI或SCE后可以输入对应模式不同波长下的反射率值。

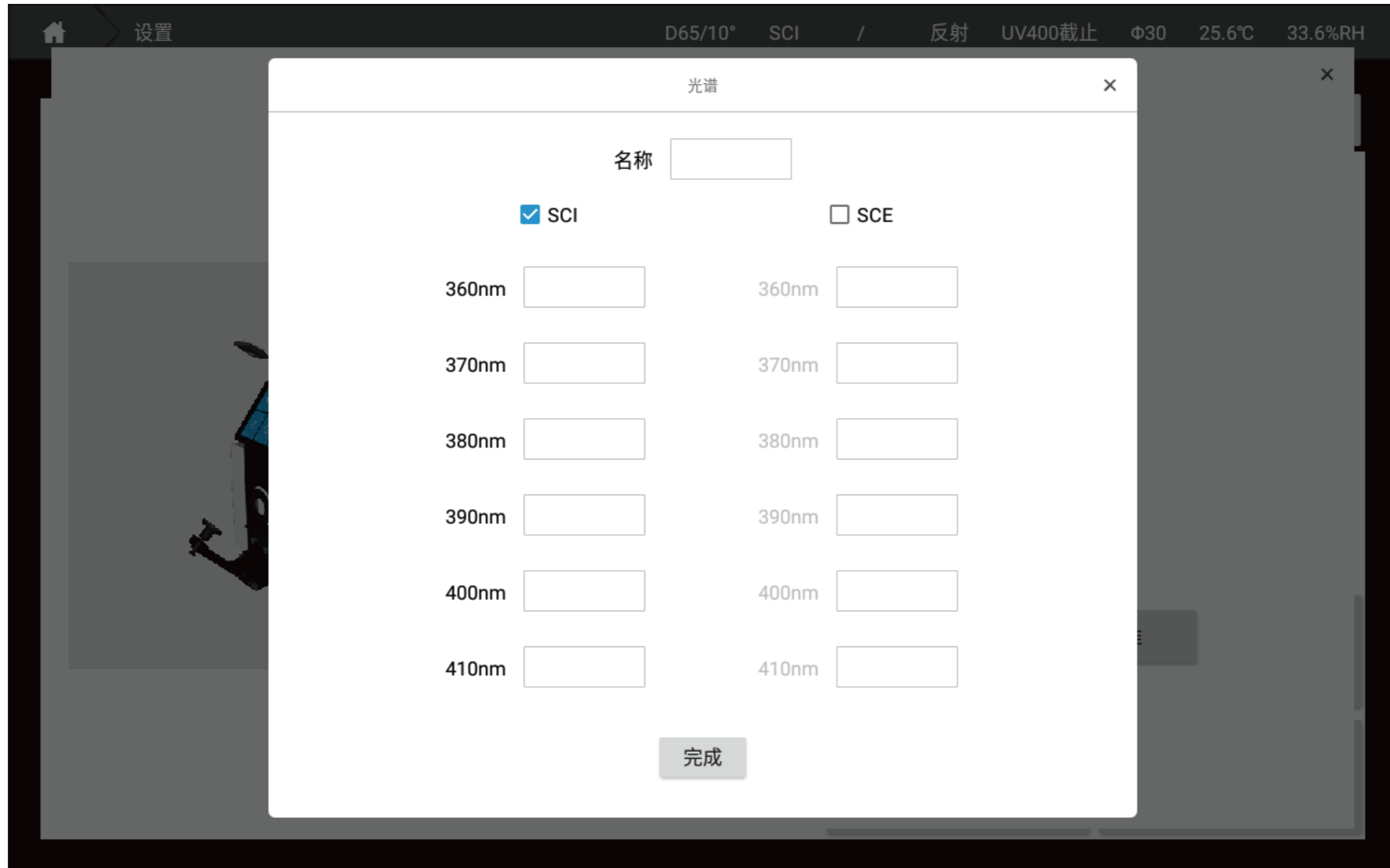

(9) EXCEL导入。选中需要导入的EXCEL文件后, 点击导入可直接导入。

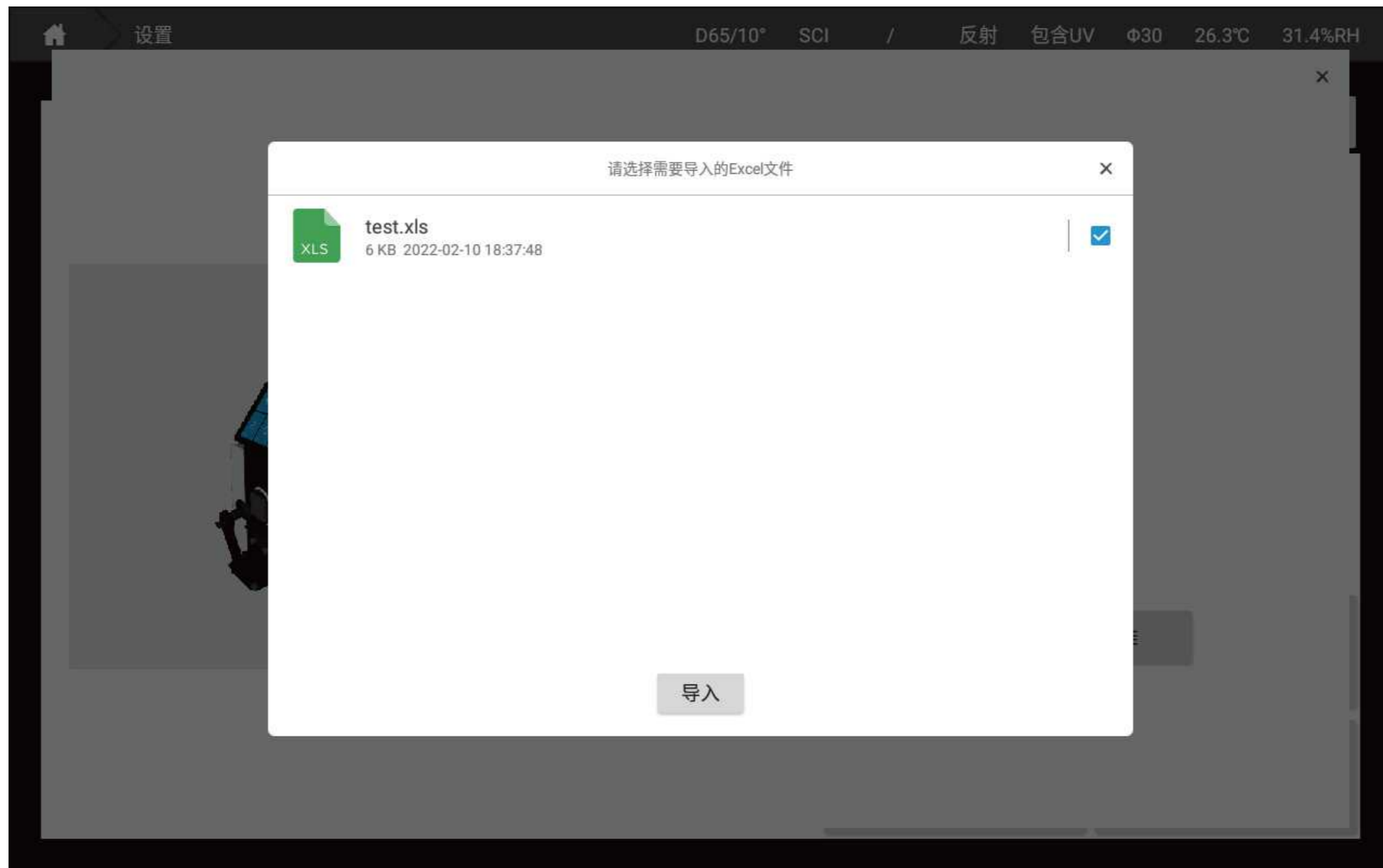

自动校准设置,可自定义黑白校准时间间隔,以及是否启用自动校准和测量校准。

(1) 点击自动校准设置,可以自定义黑白校准时间间隔,选择是否启用自动校准和测量校准。



(3) 启用或禁用自动校准、测量校准。启用自动校准后, 仪器在每次通电启动后会自动进行一次黑校准和白校准。启用测量校准后, 仪器在正常运作的空闲时间会定时进行黑校准和白校准。禁用后, 任何时间都不会自动进行黑白校准。

- ① 系统设置窗口下可以设置屏幕背光、软件显示语言。
- ② 点击恢复出厂设置, 会把仪器恢复到出厂时候的设置。
- ③ 点击屏幕旋转按钮, 屏幕会进行180°旋转。
- ④ Wifi设置, 连接或管理可用的无线网络。





## F-2

### 参数设置

参数设置可对数据计算进行配置

1、光源&角度：可以设置计算数据的光源与角度，第一光源与角度为所有模式下的计算数据，第二光源只用于计算同色异谱（注：相近色查找与我的色彩显示数据固定为D65/10°）

- 2、CMC(l:c):可以设置CMC色差公式的l:c系数;
- 3、CIE94:可以设置CIE94色差公式的KL、KC、KH系数;
- 4、CIE94:可以设置CIE2000色差公式的KL、KC、KH系数;



## 容差设置

容差用来判断测量数据是否合格的依据，当测量数据超过容差范围时将提示数据不合格，当测量数据小于等于容差时将提示数据合格。

该界面下可以设置不同色差公式以及模式的容差。（其中CIE LAB可以用户自定义提示语言）



## 显示设置

显示设置可以设置“测量页面”下显示的内容。分为如下几个：

- 1、色差：CIELABCH、CIEDE2000、CIE94、CMC、HunterLab；
- 2、数据：该模式可以显示除了雾度与遮盖力以外该仪器所有能够测量的参数；
- 3、图像：CIE LAB图、Yxy图、Luv图、反射/透过率图、K/S曲线图、吸光度曲线图；
- 4、遮盖力：测量遮盖力参数；
- 5、同色异谱：测量同色异谱参数；
- 6、液体色度：测量saybolt、ASTM color、铂钴色度、Gander color；
- 7、相近色查找：从“我的色彩”数据库中查找出当前测量数据最接近的颜色。
- 8、色母粒：专用于色母粒色度测量；
- 9、钛白粉：专用于钛白粉色度测量；
- 10、糊状物：专用于糊状物色度测量。

Home 设置 D65/10° SCI / 反射 UV400截止 Φ 30 22.2°C 25.0%RH

仪器 参数 容差 显示 其他 向导 应用

**色差**

- 数据
- 图形
- 雾度(透射)
- 遮盖力
- 同色异谱
- 液体色度(透射)
- 相近色查找
- 色母粒

**CIELABCH**

- CIEDE2000
- CIE94
- CMC
- Hunter Lab

测量 C/2° SCI 反射 包含UV Φ 18 19.1°C 46.8%RH

标样测量 — 标样0001 试样测量 — 试样0001

标样	试样	差异值	合格
L* = 98.74	L* = 98.74	dL* = 0.01	合格
a* = -0.04	a* = -0.03	da* = 0.01	合格
b* = 0.43	b* = 0.42	db* = -0.00	合格
c* = 0.43	c* = 0.42	dc* = -0.00	合格
h = 95.08	h = 94.00	dH* = -0.01	合格
		dE*ab	0.01 合格

F-4

## F-5

### 其他设置

- 1、平均设置窗口可以设置单次测量还是平均测量；
- 2、保存设置窗口可以设置手动保存还是自动保存；
- 3、命名规则窗口可以设置标样试样保存时候的名字规则；
- 4、加热模具设置可以启用加热夹具和设置目标温度。



F-5

# [数据浏览]

## G

- 1、页面左边显示的是标样数据列表，右边是标样下的试样数据列表；
- 2、页面左下方可以根据名称、时间或备注对标样或试样进行搜索和排序；
- 3、点击其中一条标样后，可以在界面右边看到标样数据下的试样数据详细信息；
- 4、长按标样或试样可以选择调出、修改、删除当前选择、删除全部、保存到我的收藏、导出报告；
- 5、点击标样进入试样详细信息界面可以搜索当前标样下的试样，可进行导出当前显示数据，上传当前显示数据；
- 6、点击参数编辑弹出参数编辑窗口，可以在这里面选择在数据界面显示的参数。

标样搜索框

标样数据列表

数据浏览 D65/10° SCI / 反射 UV400截止  $\Phi$  30 22.4°C 25.0%RH

标样	参数编辑	名称	模式	L*	a*	b*	dE
标样0001							

标样  试样 搜索 名称 ▾ 名称排序 ▲ 导出 导入

G-1

数据浏览 D65/10° SCI / 反射 UV400截止 Φ 30 22.6°C 25.8%RH

标样	参数编辑	名称	模式	L*	a*	b*	dE*
标样0003	标样	标样0003	SCI	72.44	22.23	-0.39	-
标样0002	0	试样0001	SCI	71.15	21.90	-0.24	1.1
标样0001							

标样 试样 搜索 名称 名称排序

导出 导入

试样数据列表

可进行导出当前显示数据和上传当前显示数据

G-2

数据浏览 D65/10° SCI / 反射 UV400截止  $\Phi$  30 22.5°C 25.6%RH

标样	参数编辑	名称	模式	L*	a*	b*	dE
标样0003	标样	标样0001	SCI	58.79	-11.50	5.43	-

- 调出为标样
- 修改
- 删除选中
- 删除全部
- 保存到我的收藏
- 导出报告

标样  试样 搜索 名称 名称排序 导出 导入

G-3

数据浏览 D65/10° SCI / 反射 UV400截止 Φ 30 22.4°C 25.0%RH

参数选择

色空间值	L*	<input type="checkbox"/> L* <input type="checkbox"/> a* <input type="checkbox"/> b* <input type="checkbox"/> c* <input type="checkbox"/> h	添加 删除 移除所有	已选参数 <input checked="" type="checkbox"/> L* <input checked="" type="checkbox"/> a* <input checked="" type="checkbox"/> b* <input checked="" type="checkbox"/> c* <input checked="" type="checkbox"/> h <input checked="" type="checkbox"/> dE*ab	顶端 向上 向下 底端
色空间差值	a*				
色差类型	b*				
白度	c*				
黄度	h				
黑度	X				
透射	Y				
色牢度	Z				
力份	x				
色密度					

完成

# [我的色彩]

## H

我的色彩为用户保存的数据，该数据可以用来调出做标样使用，相近色查找在该数据库中进行查找。

页面顶部：可对我的色彩库进行选择与修改，可下拉选择显示不同的库，也可以点击“管理”对色彩库进行重命名、删除等操作，也可以点击“新建”添加色彩库；

页面中间：为当前选中色彩库的下的数据展示（ $L^*$ 、 $a^*$ 、 $b^*$ 数据为D65/10° 参数下计算的数据）；

页面底部：可以对数据进行查找、显示、备份（需要插入U盘）、新增一条数据到当前色彩库、同步数据到云端、删除数据等操作。

我的色彩 D65/10° SCI / 反射 UV400截止 Φ 30 22.5°C 25.8%RH

选择： 我的色彩库 管理 新建 导入库 当前显示数据光源角度为 D65/10°

标样0001 SCI	标样0002 SCI	标样0003 SCI
L* = 58.79 a* = -11.50 b* = 5.43	L* = 26.86 a* = 26.61 b* = -20.68	L* = 72.44 a* = 22.23 b* = -0.39

请输入查找关键字 名称 查找 备份 新增 同步 删除

H-1

我的色彩 D65/10° SCI / 反射 UV400截止  $\Phi$  30 22.5°C 25.8%RH

选择： 我的色彩库 管理 新建 导入库 当前显示数据光源角度为 D65/10°

标样0001  
SCI  
L\* = 58.79  
a\* = -11.50  
b\* = 5.43

色彩库管理 ×

我的色彩库

名称 我的色彩库

备注

删除 完成

请输入查找关键字 名称 查找 备份 新增 同步 删除

H-2



H-3

我的色彩 D65/10° SCI / 反射 UV400截止 Φ 30 22.5°C 25.8%RH

选择： 我的色彩库

当前显示数据光源角度为 D65/10°

标样0001  
SCI  
L\* = 58.79  
a\* = -11.50  
b\* = 5.43

### 色彩详情

L\* = 72.44  
a\* = 22.23  
b\* = -0.39

光谱曲线图

波长 (nm)

名称

备注

创建时间：2016-01-01 11:21:28

请输入查找关键字



我的色彩

D65/10°

SCI

/

反射

UV400截止

Φ 18

23.1℃

34.5%RH

选择：

我的色彩库



管理

新建

导入库

当前显示数据光源角度为  
D65/10°

标样0013

SCI

L\* = 25.47

a\* = -0.11

b\* = -0.05

试样0001

SCI

L\* = 19.32

a\* = 1.22

b\* = -4.93

标样0008

SCI

L\* = 75.15

a\* = -0.18

b\* = 31.10

请输入查找关键字

名称



查找

备份

新增

同步

完成

H-5



我的色彩

D65/10° SCI /

反射

UV400截止

Φ 30

22.5°C

25.8%RH

选择：

标

L\* =

a\* =

b\* =

名称

备注

完成

新增我的色彩



手动输入

仪器测量

SCI

SCE

L\*:

L\*:

a\*:

a\*:

b\*:

b\*:

预览

请输入

H-6

我的色彩 D65/10° SCI / 反射 UV400截止  $\Phi$  30 22.5°C 25.8%RH

选择：

新增我的色彩

手动输入 仪器测量

SCI

L\*:

a\*:

b\*:

360nm:

370nm:

380nm:

390nm:

名称

备注

测量

完成

请输入

H-7

# [个人中心]

I-1

个人中心界面可以修改账户密码，注销当前账号。

The screenshot displays the '个人中心' (Personal Center) interface. At the top, there is a navigation bar with a home icon, the text '个人中心', and system information: 'D65/10° SCI / 反射 UV400截止 Φ 30 22.4°C 25.2%RH'. Below the navigation bar, the interface is divided into two main sections. The left section, titled '账号: admin', contains four input fields for '公司名称' (Company Name), '公司地址' (Company Address), '联系人姓名' (Contact Name), and '邮箱' (Email). The right section, titled '修改账户密码' (Change Account Password), contains three input fields for '原密码' (Original Password), '新密码' (New Password), and '确认密码' (Confirm Password), followed by a '确定' (Confirm) button. Below the '修改账户密码' section, there is a '注销' (Logout) button.

I-1

# [关于]

J-1

关于界面可以查看仪器的信息，比如软件版本，仪器版本，仪器序列号，仪器型号等等。



J-1

# [日志]

K-1

日志界面可以看到仪器的登陆信息，校准信息，仪器错误信息等。



The screenshot shows a log interface with a dark header bar. On the left is a home icon, followed by the text '日志'. On the right side of the header, there is a status bar with the following text: 'D65/10° SCI / 反射 UV400截止 Φ 30 22.5°C 24.9%RH'. Below the header is a white box containing a list of log entries. Each entry consists of a timestamp and a description. A '仪器自检' button is located in the top right corner of the log list area.

Timestamp	Event Description
2016-01-01 10:57:02.1	仪器黑校准成功
2016-01-01 10:43:29.5	仪器绿校准成功
2016-01-01 10:42:55.5	仪器白校准成功
2016-01-01 10:40:59.4	仪器白校准失败
2016-01-01 10:40:48.7	仪器黑校准成功
2016-01-01 09:55:50.2	仪器黑校准成功
2016-01-01 08:54:35.5	登录账户 admin
2016-01-01 08:45:01.6	登录账户 admin
2016-01-01 08:43:25.5	开机自检:0
2016-01-01 08:03:57.7	登录账户 admin

K-1

# [更新]

## L-1

联网情况下，可以点击更新检测是否有新软件，获取最新软件。



## L-1

# 测量界面介绍

## [色差]

M-1

### CIELABCH

在这个界面可以测量样品颜色的 $L^*$ 、 $a^*$ 、 $b^*$ 、 $c^*$ 、 $h$ 值，通过对比标样试样计算显示出 $dL^*$ 、 $da^*$ 、 $db^*$ 、 $dc^*$ 、 $dH^*$ ，以及 $dE^*_{ab}$ ，同时通过设定的容差自动判断样品是否合格。



测量

D65/10° SCI / 反射 UV400截止 Φ 18 22.9°C 35.2%RH

标样测量 --- 标样0013

试样测量 --- 试样0001

### 标样

L\* = 61.05  
 a\* = 8.12  
 b\* = 14.33  
 c\* = 16.47  
 h = 60.46

### 试样

L\* = 65.88  
 a\* = 8.04  
 b\* = 16.68  
 c\* = 18.51  
 h = 64.26

dL\* = 4.82 偏亮  
 da\* = -0.08 合格  
 db\* = 2.35 偏黄  
 dc\* = 2.05 不合格  
 dH\* = 1.16 合格

dE\*ab  
 5.36 不合格



取景



设置



报告



保存



测量

M-1

# M-2

## CIEDE2000

在这个界面可以测量样品颜色的L\*、a\*、b\*、c\*、h值，通过对比标样试样计算显示出dL'、dC'、dH'，以及dE\*2000，同时通过设定的容差自动判断样品是否合格。



M-2

# M-3

## CIE94

在这个界面可以测量样品颜色的L\*、a\*、b\*、c\*、h值，通过对比标样试样计算显示出dL\*、da\*、db\*、dc\*、dH\*，以及dE\*94，同时通过设定的容差自动判断样品是否合格。

The screenshot displays a software interface for color measurement. At the top, it shows measurement conditions: D65/10° SCI / 反射 UV400截止 Φ 18 23.2°C 33.2%RH. Below this, there are two tabs: '标样测量 -- 标样0013' and '试样测量 -- 试样0001'. The interface is divided into three main sections:

- 标样 (Standard):** L\* = 63.13, a\* = 8.52, b\* = 15.26, c\* = 17.48, h = 60.84
- 试样 (Sample):** L\* = 64.52, a\* = 7.58, b\* = 15.68, c\* = 17.41, h = 64.20
- Color Difference Results:**
  - dL\* = 1.39 合格
  - da\* = -0.94 合格
  - db\* = 0.41 合格
  - dc\* = -0.07 合格
  - dH\* = 1.02 合格
- dE\*94:** 1.61 合格

On the right side, there is a vertical toolbar with icons for '取景' (Image Capture), '设置' (Settings), '报告' (Report), '保存' (Save), and '测量' (Measure).

M-3

# M-4

## CMC

在这个界面可以测量样品颜色的L\*、a\*、b\*、c\*、h值，通过对比标样试样计算显示出dL\*、da\*、db\*、dc\*、dH\*，以及dEcmc(l:c)，同时通过设定的容差自动判断样品是否合格。

The screenshot shows a software interface for color measurement. At the top, it displays measurement conditions: D65/10° SCI / 反射 UV400截止 Φ 18 23.2°C 33.2%RH. Below this, there are two tabs: '标样测量 -- 标样0013' and '试样测量 -- 试样0001'. The '试样测量' tab is active. The interface is divided into three main sections: '标样' (Standard), '试样' (Sample), and a comparison section. The '标样' section shows L\* = 68.91, a\* = 9.90, b\* = 16.09, c\* = 18.89, and h = 58.38. The '试样' section shows L\* = 68.62, a\* = 9.92, b\* = 16.20, c\* = 18.99, and h = 58.52. The comparison section shows dL\* = -0.29 (合格), da\* = 0.02 (合格), db\* = 0.11 (合格), dc\* = 0.10 (合格), and dH\* = 0.05 (合格). At the bottom of the comparison section, it shows dEcmc(2.0:1.0) = 0.15 (合格). On the right side, there is a vertical toolbar with icons for '取景' (Screenshot), '设置' (Settings), '报告' (Report), '保存' (Save), and '测量' (Measure).

标样	试样	差值	合格
L* = 68.91	L* = 68.62	dL* = -0.29	合格
a* = 9.90	a* = 9.92	da* = 0.02	合格
b* = 16.09	b* = 16.20	db* = 0.11	合格
c* = 18.89	c* = 18.99	dc* = 0.10	合格
h = 58.38	h = 58.52	dH* = 0.05	合格
		dEcmc(2.0:1.0)	0.15 合格

# M-4

# M-5

## Hunter Lab

在这个界面可以测量样品颜色的Hunter L、Hunter a、Hunter b值，通过对比标样试样计算显示出dHunter L、dHunter a、dHunter b，以及dEab，同时通过设定的容差自动判断数据是否合格。

The screenshot displays the Hunter Lab software interface. At the top, it shows measurement parameters: D65/10° SCI / 反射 UV400截止 Φ 18 23.2°C 33.1%RH. Below this, there are two tabs: '标样测量 --- 标样0013' and '试样测量 --- 试样0001'. The interface is divided into three main sections: '标样 (Hunter)', '试样 (Hunter)', and a comparison section. The '标样' section shows L = 62.22, a = 9.41, and b = 12.98. The '试样' section shows L = 62.13, a = 9.29, and b = 13.11. The comparison section shows dL = -0.09 (合格), da = -0.12 (合格), db = 0.13 (合格), and dEab = 0.20 (合格). On the right side, there is a vertical toolbar with icons for '取景', '设置', '报告', '保存', and '测量'.

标样 (Hunter)	试样 (Hunter)	差值	合格
L = 62.22	L = 62.13	dL = -0.09	合格
a = 9.41	a = 9.29	da = -0.12	合格
b = 12.98	b = 13.11	db = 0.13	合格
		dEab	0.20 合格

M-5

# [数据]

## N-1

- 1、在数据界面可以点击参数编辑来选择你想要看的参数；
- 2、通过测量标样，然后测量试样来查看样品的参数差值；
- 3、点击数据可以选中，长按数据可以对数据进行删除，重命名等操作。

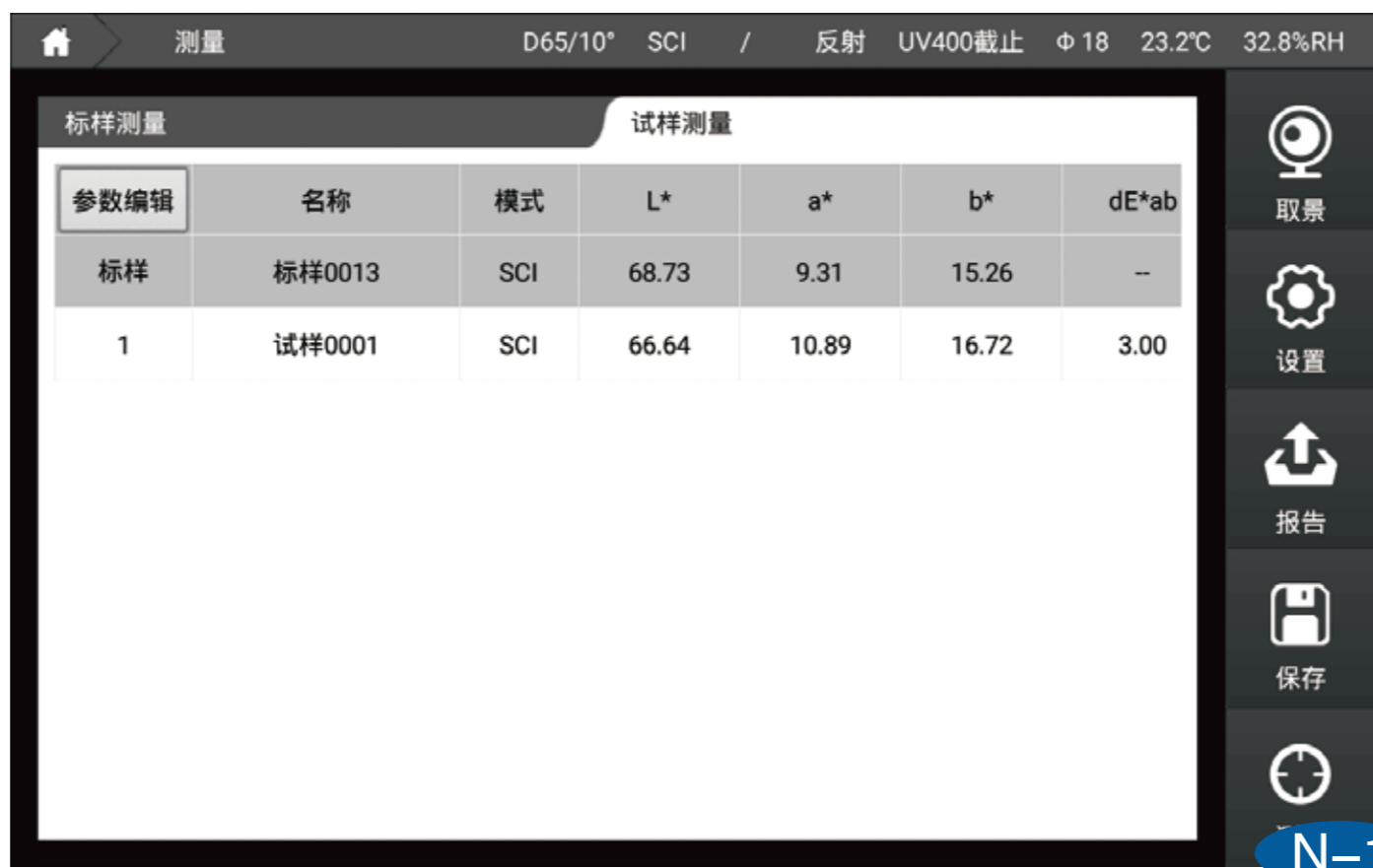

测量 D65/10° SCI / 反射 UV400截止 φ 18 23.2°C 32.8%RH

参数编辑	名称	模式	L*	a*	b*	dE*ab
标样	标样0013	SCI	68.73	9.31	15.26	--
1	试样0001	SCI	66.64	10.89	16.72	3.00

取景  
设置  
报告  
保存

N-1

# [图形]

## 0-1

### CIELAB

在该界面可以测量样品的L\*、a\*、b\*值，同时用该样品的a\*、b\*值在CIELAB图上描点并显示数据的L\*、a\*、b\*值。

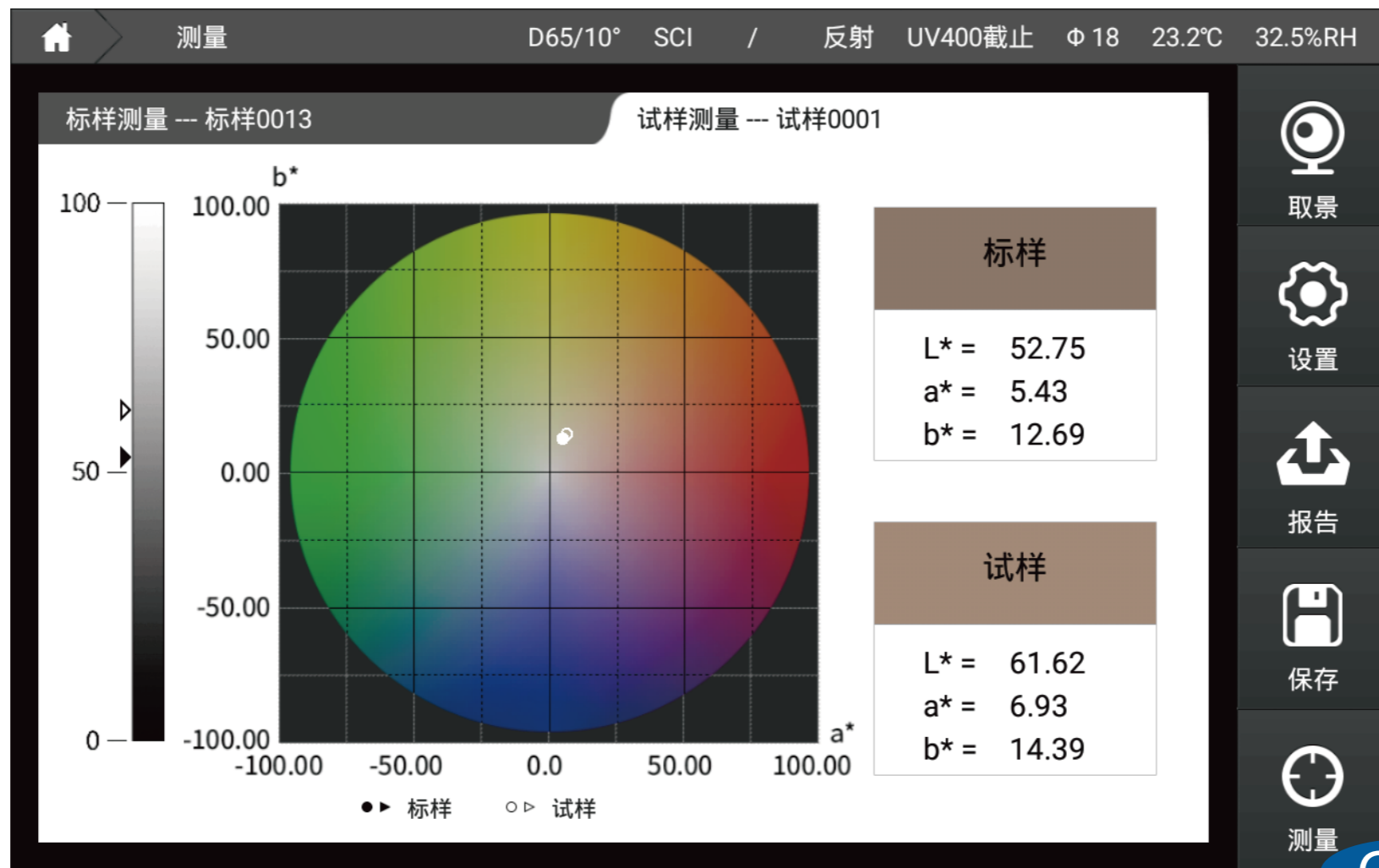

## 0-1

0-2

## Yxy

在该界面可以测量样品的Y、x、y值，同时用该样品的x、y值在Yxy图上描点并显示数据的Y、x、y值。

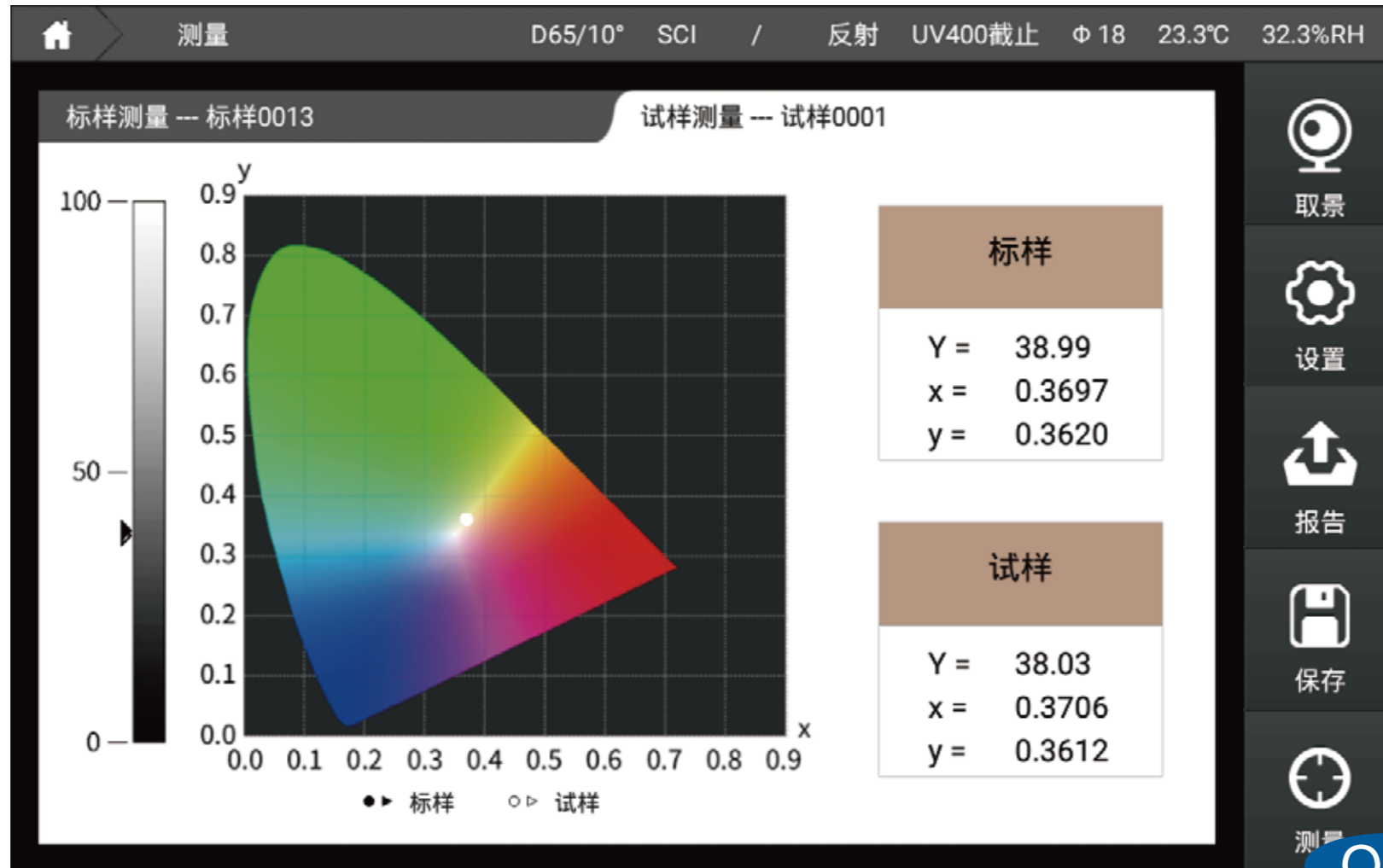

0-2

# 0-3

## Luv

在该界面可以测量样品的 $L^*$ 、 $u^*$ 、 $v^*$ 值，同时用该样品的 $u'$ 、 $v'$ 值在Luv图上描点并显示数据的 $L^*$ 、 $u^*$ 、 $v^*$ 值。

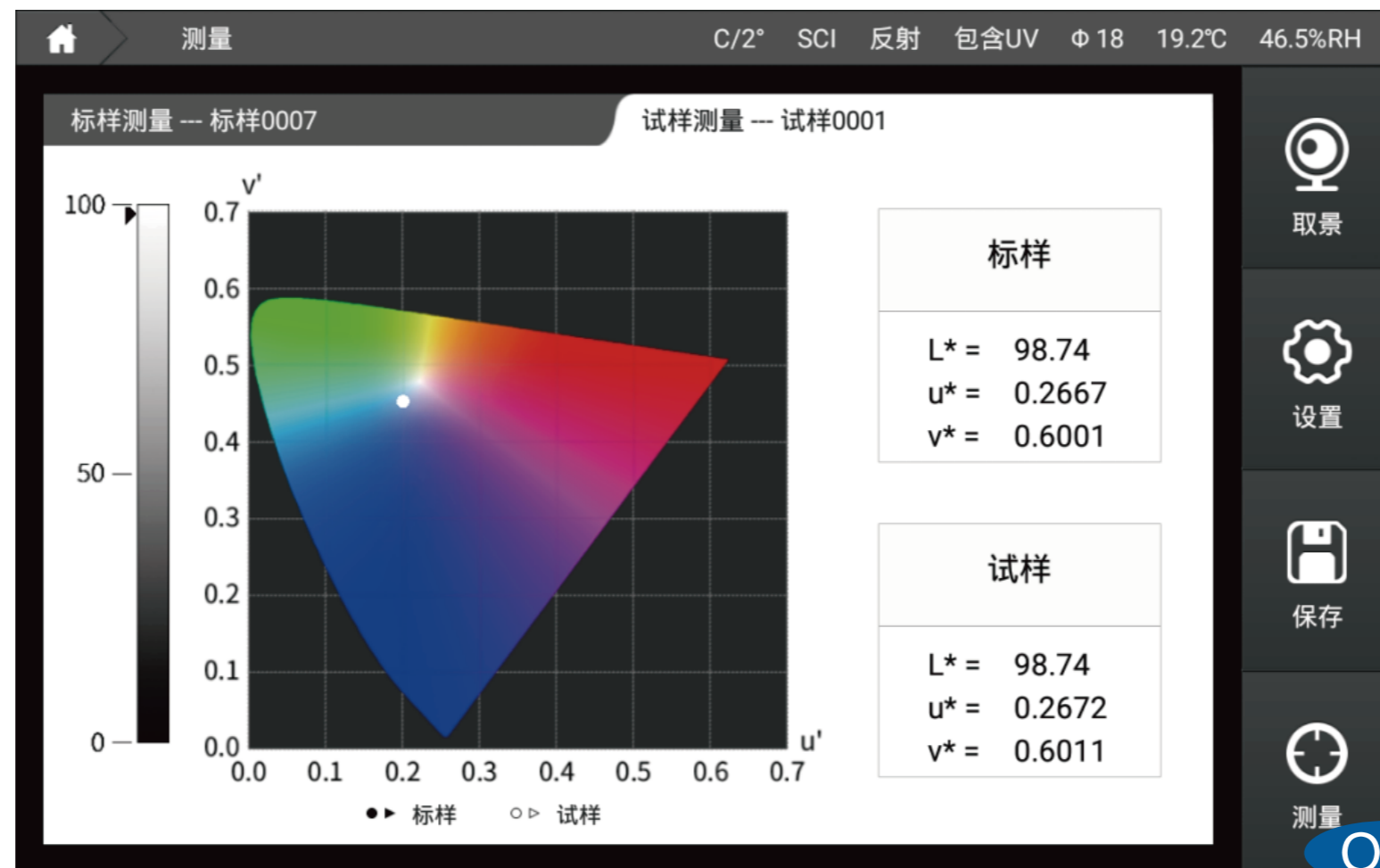

# 0-3

0-4

## k/s曲线

在该界面可以测量样品的k/s值，同时显示360-780nm下的K/S曲线图。



0-5

## 反射率曲线

在该界面可以测量样品的反射率值，同时可以显示360-780nm下的反射率曲线图。

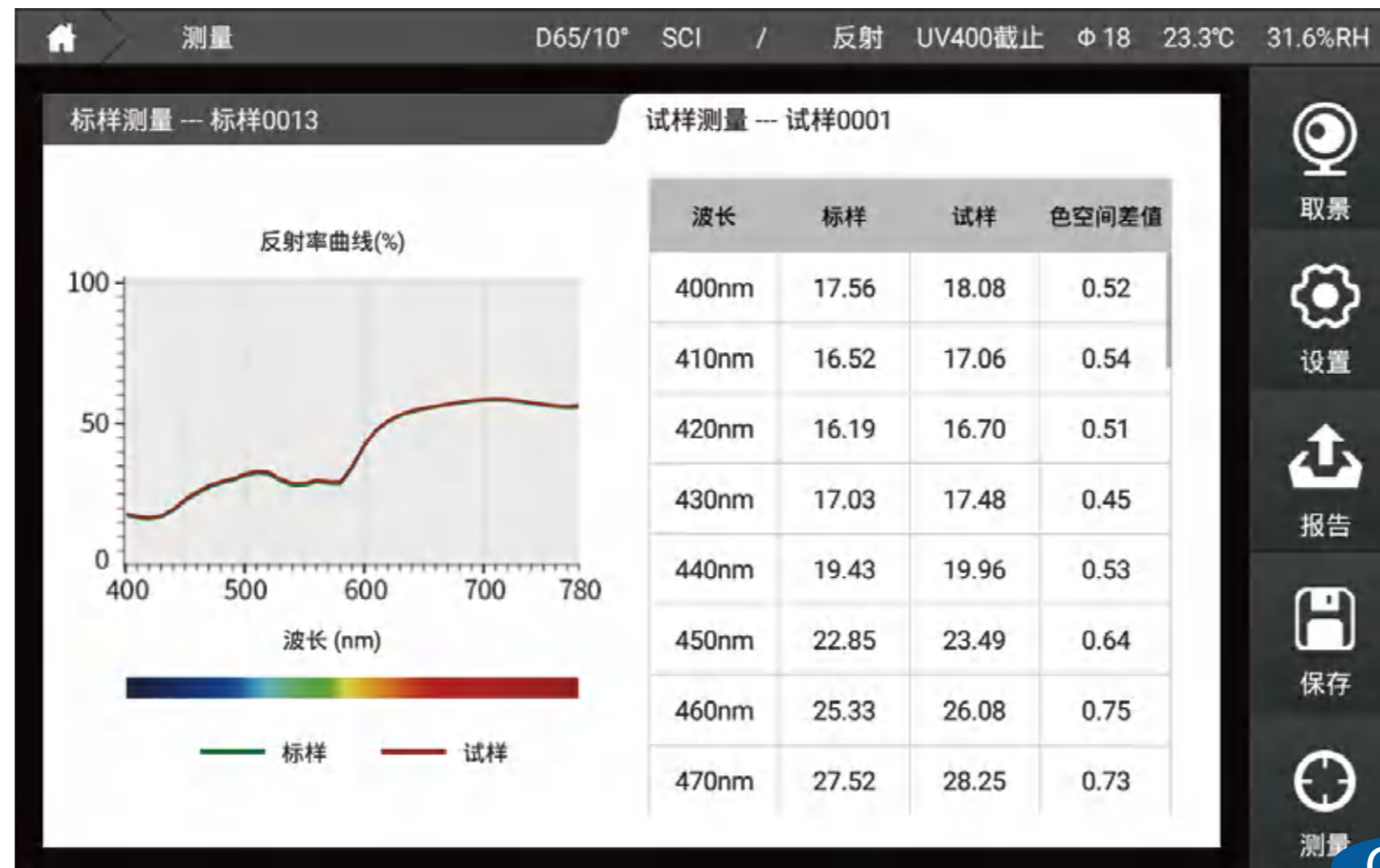

0-5

# 0-6

## 透过率曲线

在该界面可以测量样品的透过率值，同时可以显示360-780nm下的透过率曲线图。

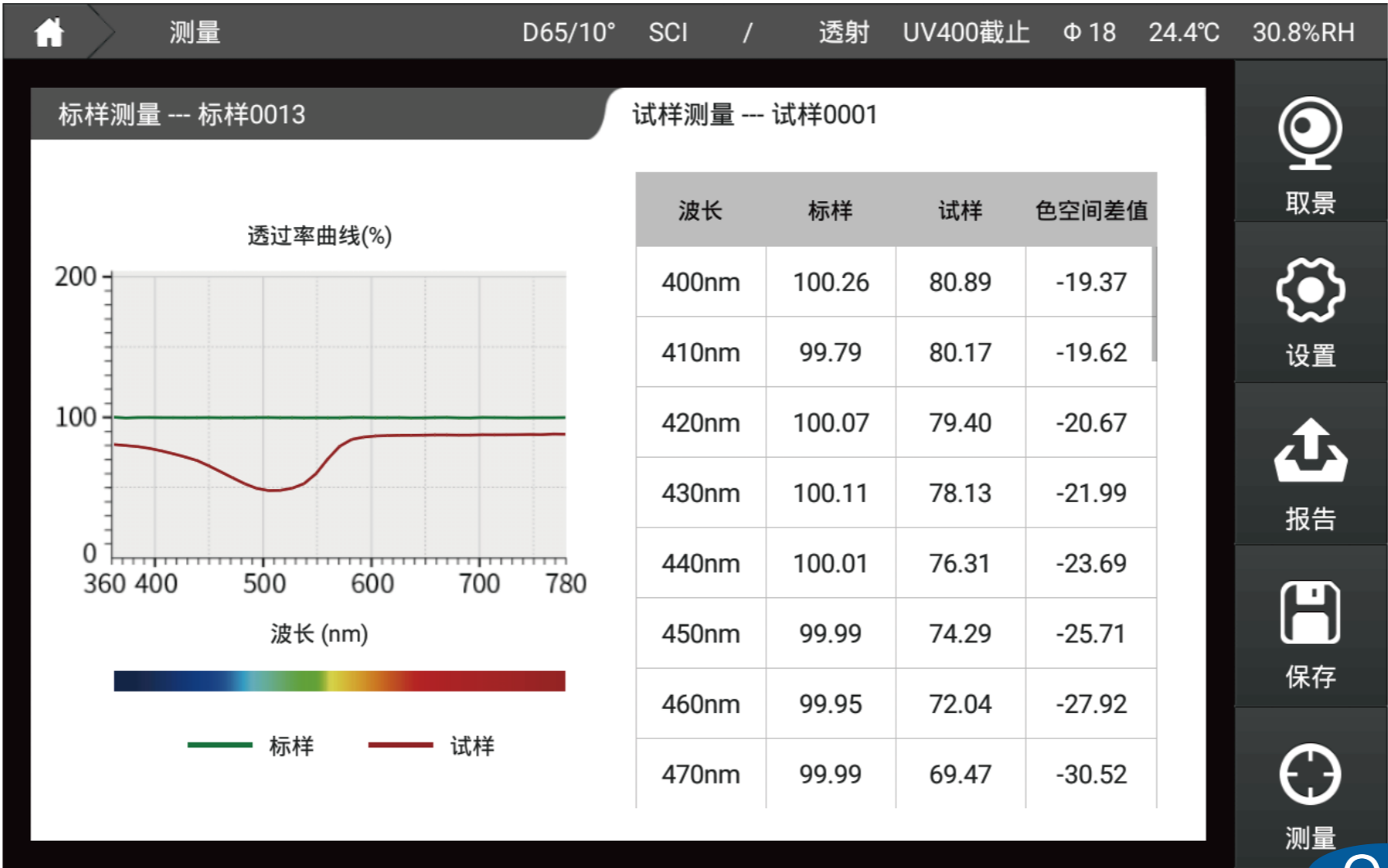

# 0-6

0-7

## 吸光度曲线

在该界面可以测量样品的吸光度值，同时可以显示360-780nm下的吸光度曲线图。

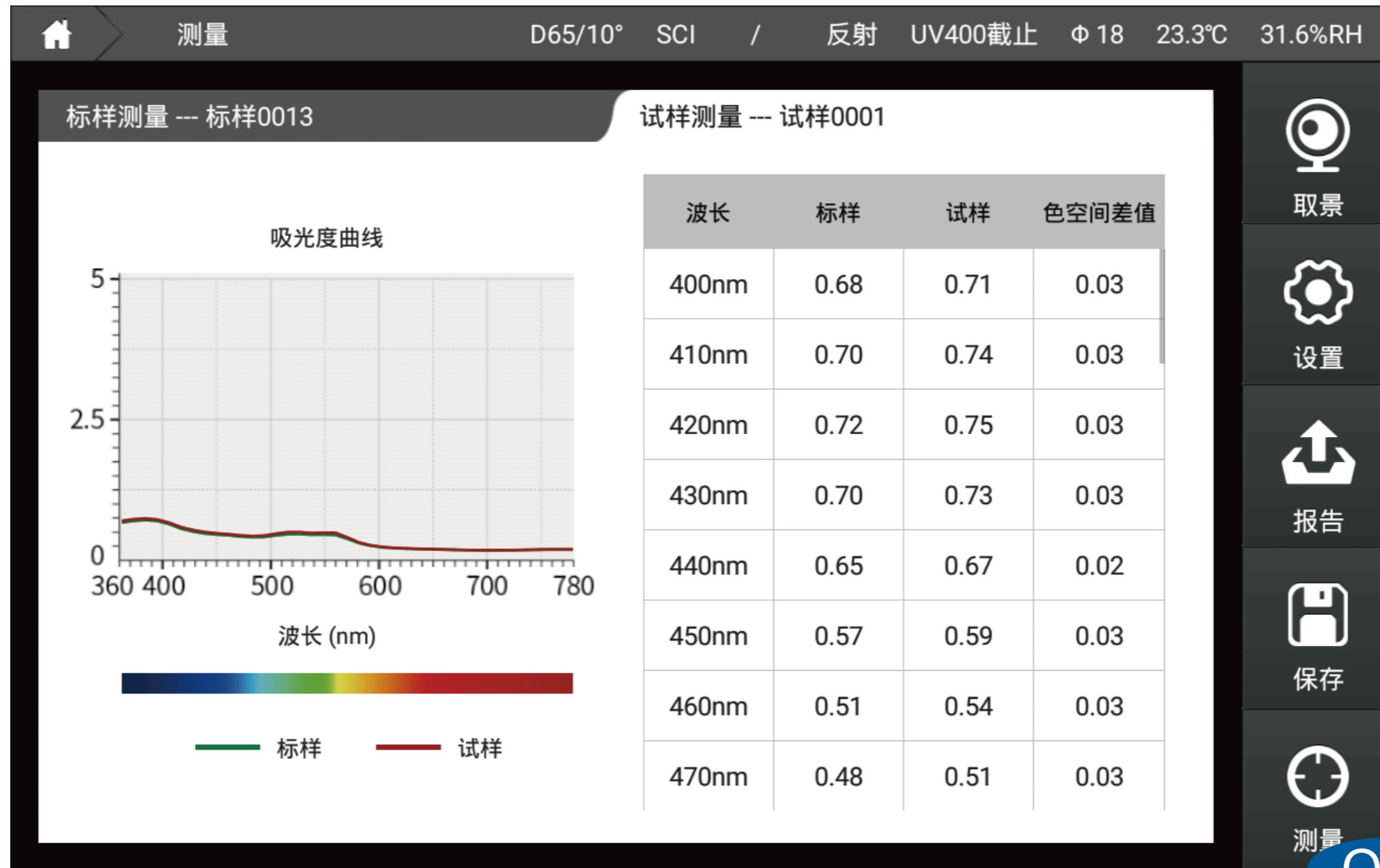

0-7

# [雾度]

## P-1

应用为雾度测量后，仪器自动切换为透射模式，C光源和2° 视角；  
测量雾度需要两次测量步骤：

- 1、在反射测量口放置白板，透射测量口放置样品进行测量；
- 2、在反射测量口放置黑腔，透射测量口放置样品进行测量。

进入雾度页面首先要进行参考校准，按照提示进行参考校准后可以测量样品数据，参考每次开机或切换到雾度页面只需要进行一次。



测量

C/2°

SCI

/

透射

UV400截止

Φ 18

23.6℃

30.7%RH

标样测量 --- 标样0013

试样测量 --- 试样0001

透过率曲线(%)

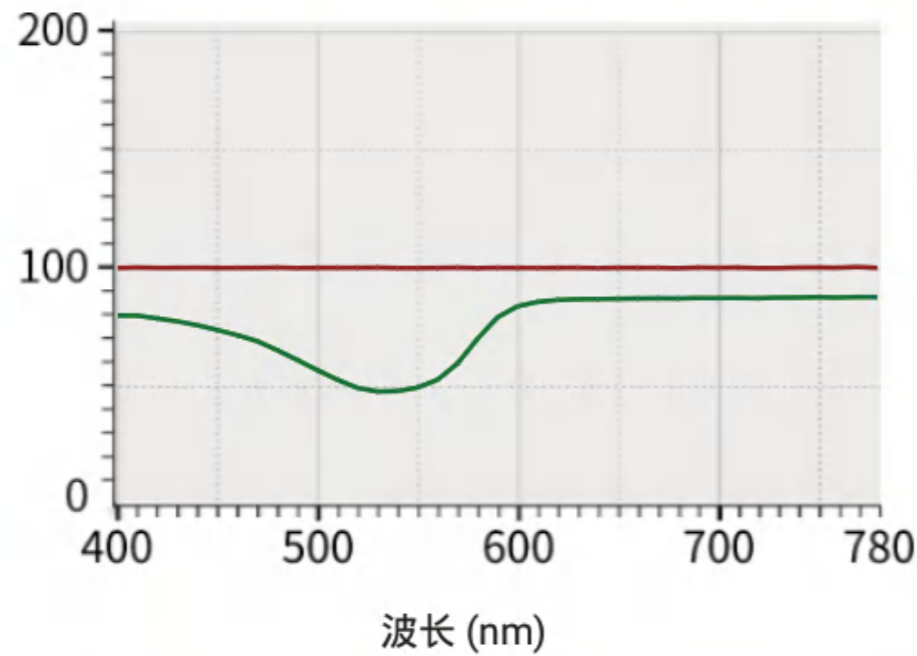

— 标样 — 试样

切换

光源/角度 C/2°

	雾度	总透过率
标样	10.24	61.99
试样	0.00	99.90
色空间差值	-10.24	37.90
判断	不合格	不合格



取景



设置



报告



保存



测量

P-1

# [遮盖力]

## Q-1

- 1、测量遮盖力需要两次测量，按照提示进行操作：第一步将刮在白色底色上的样品进行测量，第二部将刮在黑色底色上的样品进行测量；
- 2、界面左边显示物体在黑色底色上测量的 $L^*$ 、 $a^*$ 、 $b^*$ 、 $Y$ 值，右边显示物体在白色底色上测量的 $L^*$ 、 $a^*$ 、 $b^*$ 、 $Y$ 值。
- 3、试样测量界面可以分别进行白色底色和黑色底色的 $L^*$ 、 $a^*$ 、 $b^*$ 、 $Y$ 值的对比并计算显示出 $dL^*$ 、 $da^*$ 、 $db^*$ 、 $dc^*$ 、 $dE^*$ 、 $dY$ ,对比标样计算并显示 $dOpacity$ 。

测量 D65/10° SCI / 反射 UV400截止 ϕ 18 23.3°C 31.5%RH

标样测量	试样测量
<p><b>标样</b></p> <p>遮盖力 <b>719.8%</b></p> <p>Y = 15.96    Y = 2.22</p>	<p><b>试样</b></p> <p>遮盖力 <b>94.9%</b> dOpacity=-624.9%</p> <p>Y = 24.61    Y = 25.94 dY=9.99      dY=23.73</p>
<p>L* = 46.92 a* = 11.83 b* = 11.48</p>	<p>L* = 16.59 a* = 4.97 b* = 4.94</p>
<p>L* = 56.69 a* = 13.97 b* = 11.84 dL*=11.06 da*=3.42 db*=1.36 dE*ab=11.66</p>	<p>L* = 57.98 a* = 15.26 b* = 12.84 dL*=41.40 da*=10.28 db*=7.90 dE*ab=43.38</p>

取景  
设置  
报告  
保存  
测量

Q-1

# [同色异谱]

R-1

界面左边是测量样品使用第一光源/角度计算出来的数值，右边是测量样品使用第二光源/角度计算出来的数值，界面中见下面的同色异谱值是样品在两光源角度下计算出来的同色异谱数值。



R-1

# [液体色度]

## S-1

- 1、应用为液体色度测量时，仪器自动设置为透射模式、C光源、2° 视角；
- 2、界面左边比色皿光程是测量不同参数推荐的比色皿光程大小(例如您想测量saybolt参数，这个时候推荐的比色皿光程大小是50mm)，右边是参数的数值，以及是否合格判断。

The screenshot shows the instrument's measurement interface. At the top, it displays '测量' (Measurement) and various settings: 'C/2° SCI / 透射 UV400截止 Φ 18 23.6°C 30.6%RH'. Below this, there are two tabs: '标样测量 -- 标样0013' and '试样测量 -- 试样0001'. A '切换' (Switch) button is present, and the current settings are '光源/角度 C/2°'. The main area contains a table with the following data:

比色皿光程	参数	标样	试样	色空间差值	判断
10mm	Pt-Co/Hazen/APHA	1.03	0.57	-0.46	合格
10mm	Gardner Color	0.00	0.00	0.00	合格
50mm	Saybolt	30	30	0	合格
33mm	ASTM Color	0.3	0.3	-0.0	合格

On the right side of the interface, there are several icons: '取景' (View), '设置' (Settings), '报告' (Report), '保存' (Save), and '测量' (Measurement).

S-1

# [相近色查找]

## T-1

- 1、进入相近色查找界面时如果设置光源角度测试模式不是D65/10/SCI的话，点进来会提示您是否设置为D65/10/SCI，点击是，这个时候会自动把仪器光源角度设置为D65/10° 测试模式设置为SCI;
- 2、界面左边是当前测量颜色的L\*、a\*、b\*数据，数据下面是色彩集，色彩集里面的内容是我的色彩界面中保存的色彩库，再往下是查找条数设置1到20条可以设置;
- 3、界面右边是查找出来的相近颜色数据。通过选择色彩集，来确定查找相近色的色彩库，然后选择查找条数来需要右边界面显示的查找到相近色数据条数；每次测量样品后，更换色彩集，重新选择查找条数后都会更新右边查找的数据颜色信息。

测量
D65/10° SCI / 反射 UV400截止 Φ 18 23.4°C 31.3%RH



$L^* = 59.13$   
 $a^* = 7.76$   
 $b^* = 14.15$

色彩集：我的色彩库

查找条数：6

查找结果

标样0008





$L^* = 75.15$   
 $a^* = -0.18$   
 $b^* = 31.10$   
 $dE^*ab = 24.64$

标样0013

$L^* = 25.47$   
 $a^* = -0.11$   
 $b^* = -0.05$   
 $dE^*ab = 37.36$

试样0001

$L^* = 19.32$   
 $a^* = 1.22$   
 $b^* = -4.93$   
 $dE^*ab = 44.63$

  
 取景
   
  
  
 设置
   
  
  
 报告
   
  
  
 保存
   
  
  
 测量

T-1

# [色母粒]

## U-1

该界面专用于色母粒测量，按照提示进行测量。界面右上角有参数设置，可以添加最多显示10个参数。



U-1

# [钛白粉]

## V-1

该界面专用于钛白粉测量，按照提示进行测量。界面右上角有参数设置，可以添加最多显示10个参数。



## V-1

# [糊状物]

## W-1

该界面专用于糊状物测量，按照提示进行测量。界面右上角有参数设置，可以添加最多显示10个参数。



# 异常处理分析

异常情况	分析	处理方法
1、仪器无法开机	电源连接可能异常	检查电源接口处是否接触良好，并插好电源
2、校准失败	<ol style="list-style-type: none"> <li>1、黑校准的时候可能放置了白板</li> <li>2、白校准的时候是否放置了黑腔</li> <li>3、透射校准的时候没有按照指示图操作</li> </ol>	<ol style="list-style-type: none"> <li>1、确保黑校准使用出厂自带黑腔，白校准使用出厂自带白板</li> <li>2、透射模式下校准请按照仪器指示图操作</li> </ol>
3、测量结果报错	容差设置可能异常	检查容差设置并调整
4、测试数值异常	<ol style="list-style-type: none"> <li>1、样品与测量口贴合紧密与否</li> <li>2、样品表面损伤是否较大</li> <li>3、查看仪器是不是在透射模式下，从反射口径测量样品</li> </ol>	<ol style="list-style-type: none"> <li>1、检查样品与测量口的贴合情况，保证紧密贴合</li> <li>2、检查样品表面情况，保证样品是完好的对测量没有影响的</li> <li>3、检测测量模式，先把仪器设置到相应的测量模式下</li> </ol>
5、口径识别错误	<ol style="list-style-type: none"> <li>1、可能是没有放置测量口径板</li> <li>2、可能把口径板放反了</li> </ol>	<ol style="list-style-type: none"> <li>1、检查仪器反射测量口径位置是否有放置口径板</li> <li>2、检查放置的口径板是否正确的放置，把口径板翻面放置试试</li> </ol>

# 附件

## 标配件

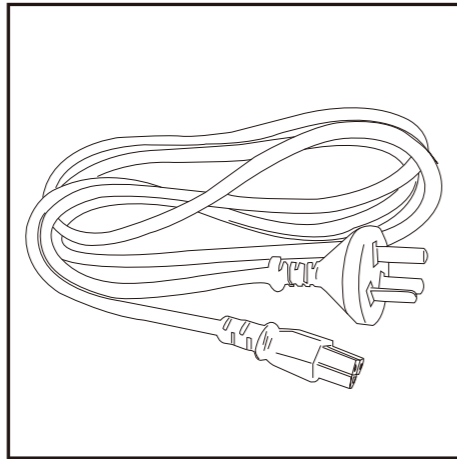

外部电源适配器

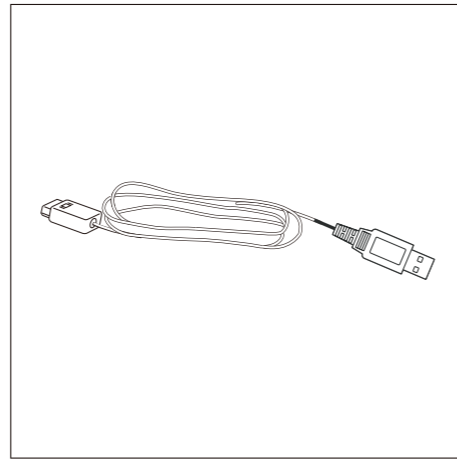

USB数据线

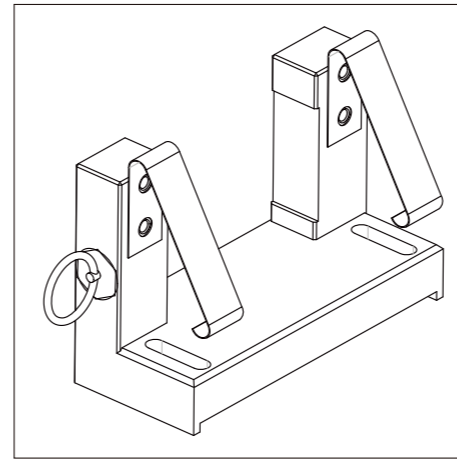

透射夹具

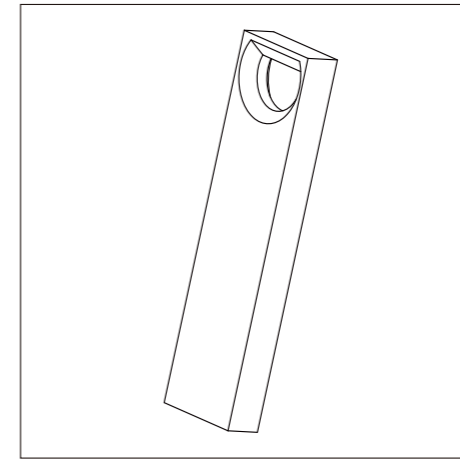

USB盘

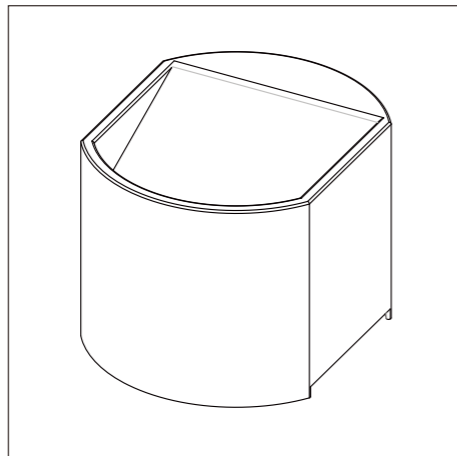

黑腔

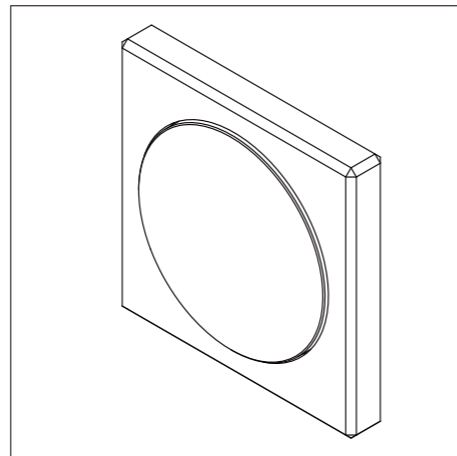

白板

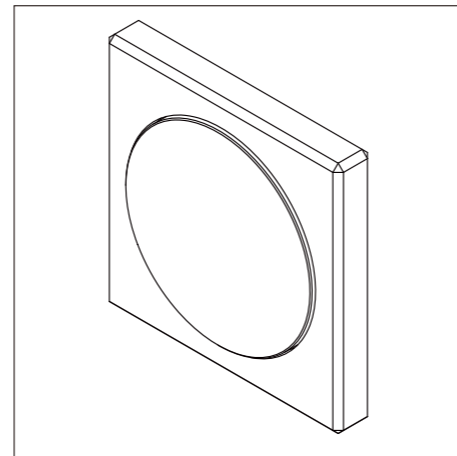

绿板

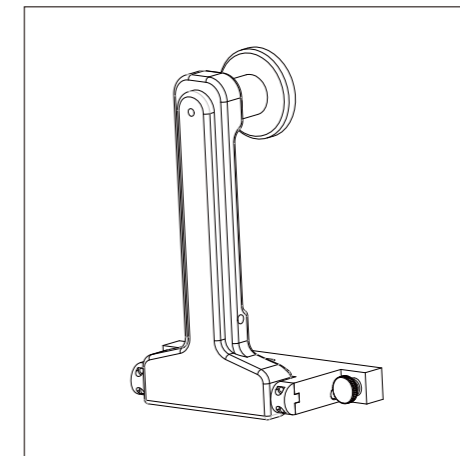

阻尼把手

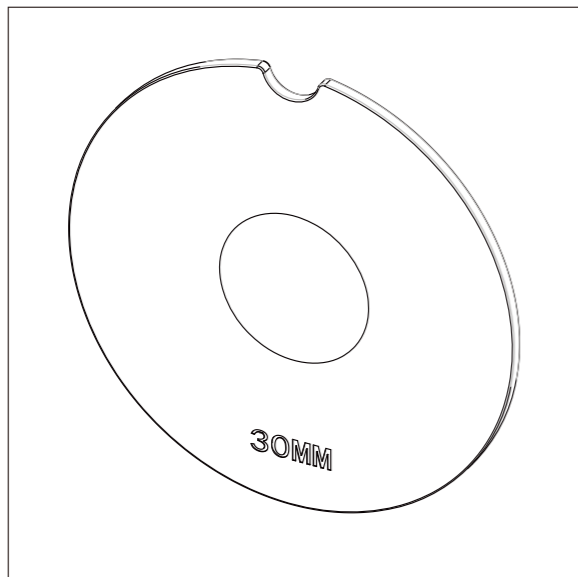

30mm口径板

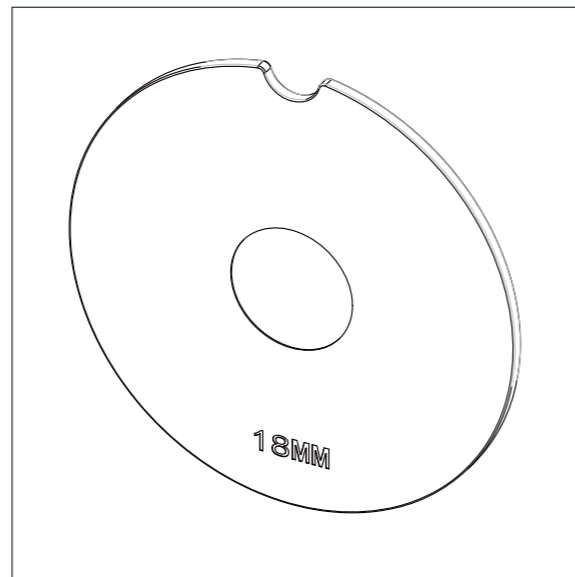

18 mm口径板

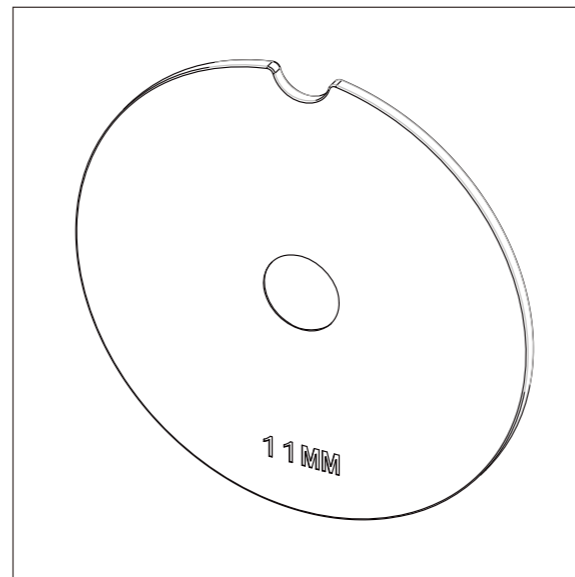

11 mm口径板

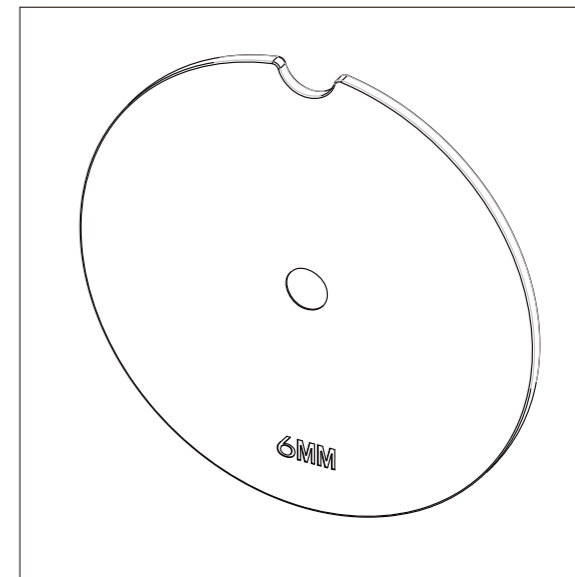

6 mm口径板

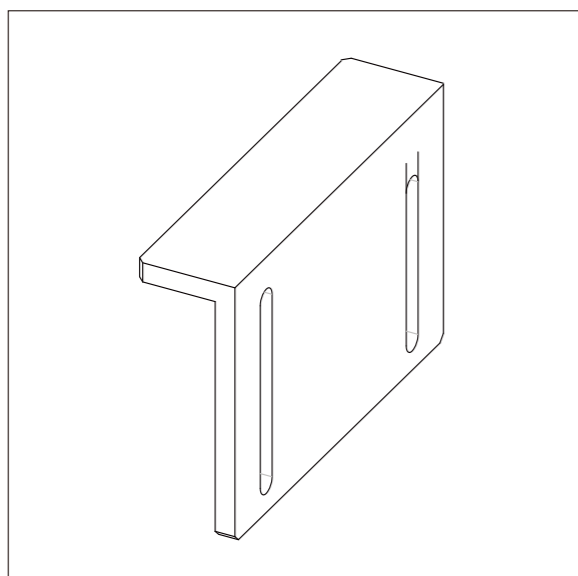

支撑台

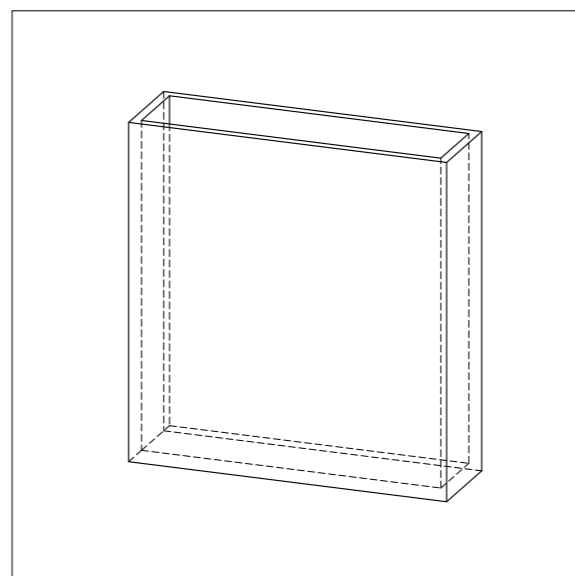

比色皿

## 选配件

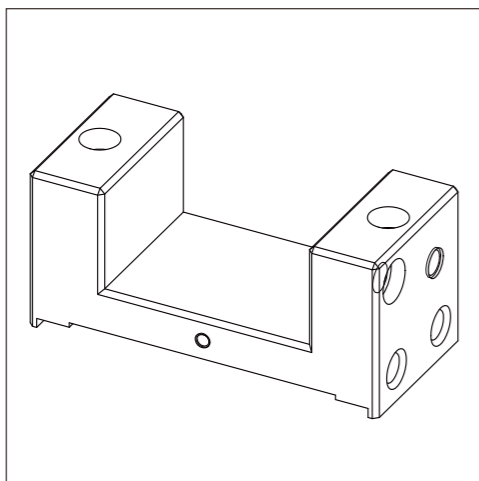

加热透射夹具  
(含控制电路)

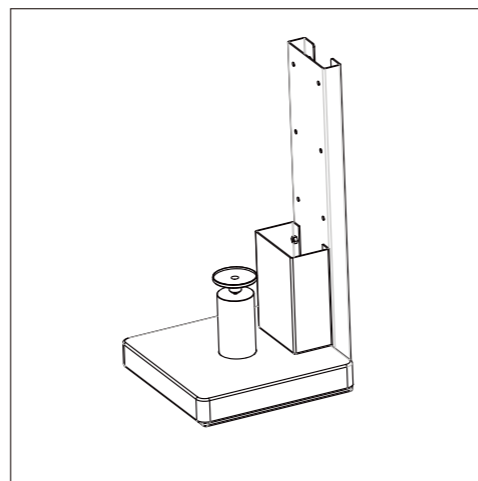

立式支架

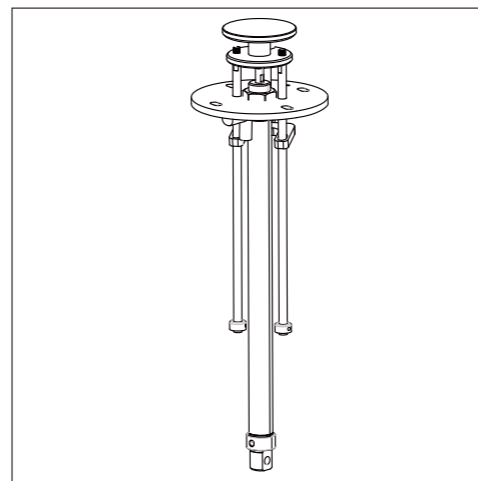

气动测量顶杆  
(含控制电路)

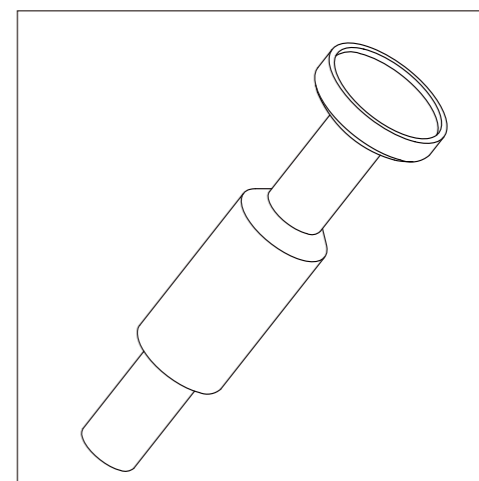

小样品夹持配件

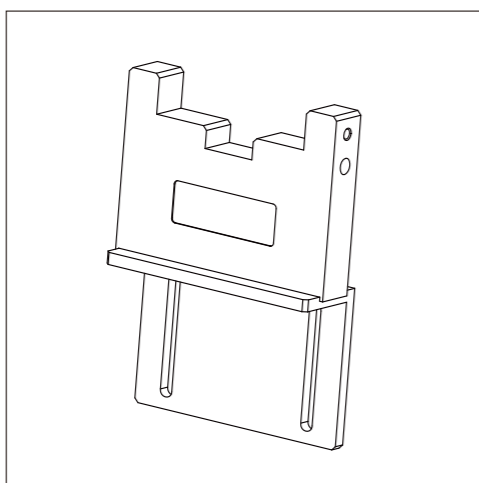

反射比色皿支架

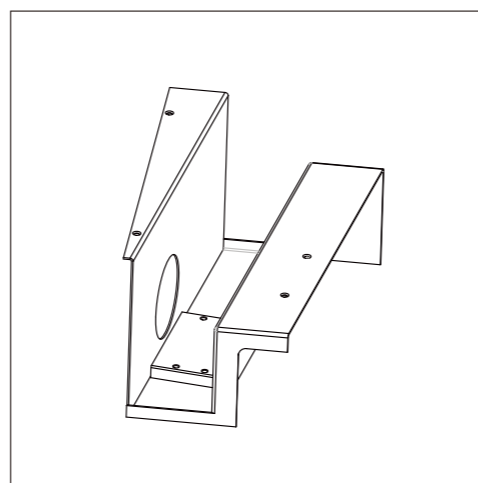

耐腐蚀防护板  
(不可拆卸)

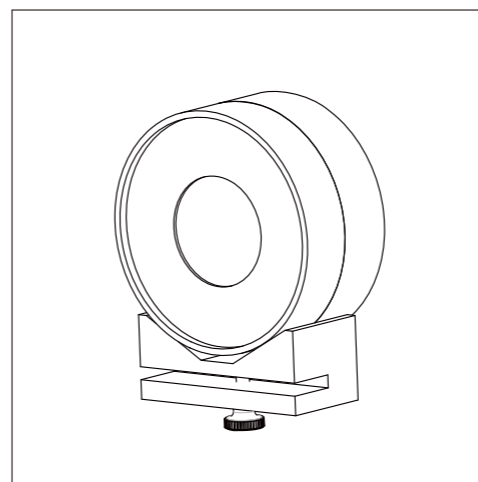

纤维测试盒

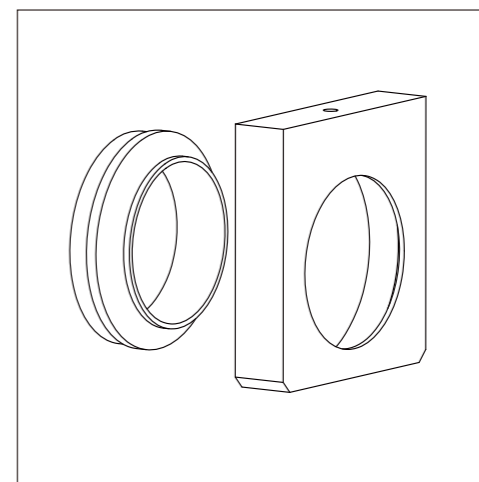

薄膜测试夹具

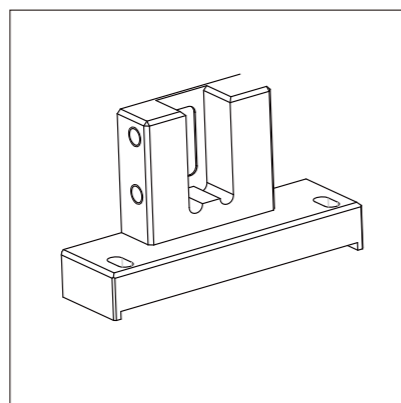

微量透射夹具



拉杆箱

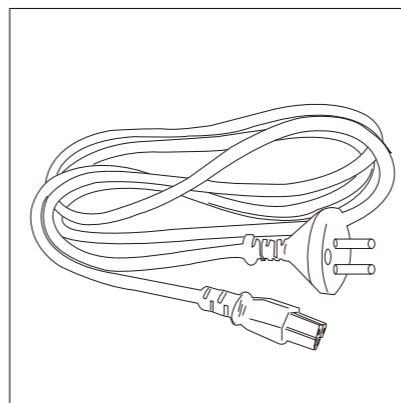

欧标插头

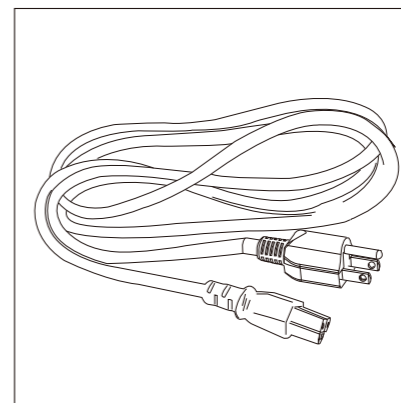

美标插头

## 公司声明

- 本公司向用户承诺，本产品保修期限为购买之日起的三年时间内有效，正常使用情况下非人为造成的故障问题，本公司将负责给予免费维修，超过保修期或人为因素导致的故障，本公司将提供维护，将收取维修材料及相关费用。
- 本公司对于第三者因使用本产品引起的任何损失或索赔不负任何责任。
- 本公司对由于故障、维修、断电或更新软件造成的数据丢失而导致的任何损害或损失均不负任何责任。为防止重要数据的丢失，请务必对所有重要数据进行备份。
- 本产品中预置的所有作品之版权归本公司所有，受《中华人民共和国著作权法》保护。
- 我公司出售本产品的行为不代表向用户转让或授予与作品版权相关的任何权利。
- 本说明书所提到的产品规格及信息仅供参考，内容会随时更新，恕不另行通知。

# Operate Manual

---

# CATALOGUE

---

[ I ] Terms of Use	01
[ II ] Notes	02
[ III ] Instrument Functions	03
[ IV ] Technical Specifications	04
[ V ] Appearance and Structure	06
[ VI ] Measurement Flow Chart	09
[ VII ] Software Interface Introduction	11
7.1 Function Introduction	11
7.2 Software Login	13
7.3 Guide	16
7.4 Calibrate	23
7.5 Measure	29
7.6 Setting	33
7.7 Data View	51
7.8 My Color	56

7.9 Individual Center	64
7.10 About	65
7.11 Daily Record	66
7.12 Update	67
[ VIII ] Measurement Interface Introduction	68
8.1 Color Diff	68
8.2 Data	74
8.3 Figure	75
8.4 Haze	82
8.5 Opacity	84
8.6 Metamerism	85
8.7 Liquid Chromaticity	86
8.8 Find Similar Color	87
8.9 Color Master Batches	89
8.10 Titanium Dioxide	90
8.11 Paste	91
[ IX ] Trouble Shooting	92
[ X ] Accessories	93
[ XI ] Company Statement	96

# Term of Use

- 1.This instrument is designed to measure the reflectance value/figure, chromaticity value, color difference value,pass/fail result,color simulation,etc with the advantage of compact structure, light weight, high test accuracy. and simple operation.
- 2.This instrument is widely used in factories, labs and on spot. It can achieve great color measurement result in the quality control of almost all fields.
- 3.Instrument warranty time starts from the purchase date. If you need any service, please contact local agent to contact us.
- 4.To avoid damage to instrument accuracy or precision, please do not disassemble the instrument. Damage to the instrument caused bydisassembly or improper use is NOT included in the warranty.

# Notes

- 1.This instrument is a precision instrument and cannot withstand collisions caused by falling. Please place it in a flat place.
- 2.This instrument is not moisture proof,Please store the instrument in dry environment.
- 3.Instrument screen is made by glass which can be damaged by external force or sharp materials.
- 4.We recommend to use original power adaptor.
- 5.To ensure the machine to work properly, please do not store, or use it in places that are too hot or too cold; please do not put the machine in damp environment, or directly under sunlight. Do not use it in severe environment such as strong shock or quake.
- 6.Please avoid strong electromagnetic interference in usage.
- 7.Please keep the instrument steady; do not shake the instrument in usage.
- 8.Please power off the instrument after usage and keep it into power off status if do not use it.

9. Please store the instrument in a dry area.

10. Users are forbidden to clean the inner sphere by themselves.

11. Any problem, please contact with us, we will solve for you asap. Please do not repair it by yourself.

12. If this user manual is further updated, we are not obliged to notify. Any questions, please contact us directly

## Instrument Functions

1. Conform to CIE No.15, GB/T 3978, GB 2893, GB/T 18833, ISO7724/1, DIN 5033 Teil7, - JIS Z8722 Condition C, ASTM E1164.

2. Can test both reflectance for opaque materials and transmittance for clear and transparent materials.

3. Simultaneous measurement of SCI (specular component included) and SCE (specular component excluded)

4. It adopts pulse xenon lamp and provides wider wavelength range.

5. Open measurement area which makes it unlimited on sample sizes.

- 6. Adopt 7.0 inches touch screen, friendly operation interface.
- 7. U disk to transfer data and data can be viewed from PC.
- 8. Different parameters to choose to meet customers' different requirement.
- 9. Instrument comes with professional PC software to generate and manage test report.

## Technical Specifications

Illumination/ Viewing System	Reflection: d/8(Diffused illumination, 8 degree viewing) Simultaneous measurement of SCI/SCE (CIE No.15, BG/T 3978, GB/T 2893, GB/T 18833, ISO7724/1, DIN 5033, ASTM E1164, Teil7, JIS Z8722 Condition C standard, ASTM-D1003-07) Transmittance d/0(Diffused illumination, 0 degree viewing )
Sensor	Dual high precision CMOS array sensor
Grating Mode	Concave Grating
Sphere Diameter	152mm
Wavelength	360-780nm
Wavelength Pitch	10nm
Spectral Half Bandwidth	1nm
Reflectance Range Resolution	0~200%, Resolution 0.01%
Light Source	Pulse Xenon Lamp+LED

UV Measurement	Include UV, 400nm cut, 420nm cut, 460nm cut
Measurement Time	SCI/SCE < 2s, SCI+SCE < 4s
Measurement Aperture	Reflectance: XLAV $\Phi$ 25.4mm/ $\Phi$ 30mm, LAV $\Phi$ 15mm/18mm, MAV $\Phi$ 8mm/ $\Phi$ 11mm, SAV $\Phi$ 3mm/ $\Phi$ 6mm (Aperture size can be custom made) Auto aperture size recognition Transmittance: $\Phi$ 17mm/ $\Phi$ 25mm
Transmittance Sample Size	No limit on sample width and height, thickness $\leq$ 50mm
Long term repeatability	XLAV Chromaticity value: Standard deviation within $\Delta E^*ab$ 0.015 (20 °C $\pm$ 10 °C arbitrary temperature change, white tile is measured every hour within 24 hours)
Repeatability	$\Delta E^*ab \leq 0.01$ Spectrum Reflectance/Transmittance: $\leq 0.1\%$ (When a white calibration plate is measured 30 x at 5-second intervals after white calibration)
Inter-Instrument Agreement	XLAV $\Delta E^*ab$ 0.2(BCRA Series II, Average measurement of 12 tiles, at 23°C)
Viewing Angles	2° and 10°
Illuminants	A,C,D50,D55,D65,D75,F1,F2,F3,F4,F5,F6,F7,F8,F9,F10,F11,F12,CWF, U30,DLF,NBF,TL83,TL84
Language	Chinese Simplified, English, Chinese Traditional, Russian, Spanish, Portuguese, Japanese, Thai, Korean, German, French, Polish
Display	Reflectance and Transmittance graph/value, color value, color difference values, pass/fail, color simulation, color assessment, haze, liquid chromaticity values, color tendency

Color Spaces	L*a*b, L*C*h, Hunter Lab, Yxy, XYZ
Other Indices	WI(ASTM E313-00,ASTM E313-73,CIE/ISO, AATCC, Hunter, Taube Berger, Stensby) YI(ASTM D1925,ASTM E313-00,ASTM E313-73),Tint(ASTM E313-00,CIE,Ganz), Metamerism index milm, stain fastness, color fastness, ISO brightness, R457, A density, T density, E density, M Density, APHA/Pt-Co/Hazen, Gardner, Saybolt, ASTM color, Haze, Total Transmittance, Opacity, Color Strength
Color Difference	$\Delta E^*ab, \Delta E^*CH, \Delta E^*uv, \Delta E^*cmc, \Delta E^*94, \Delta E^*00, \Delta Eab(Hunter), 555$ shade sort
Storage Memory	8GB
Screen Size	10 Inches Touch Screen
Operate System	Andriod
Power	DC stabilized power supply
Operate Temperature	5-40°C(40-104F), relative humidity 80% (at 35°C) no condensation
Storage Temperature	-20-45°C(-4-113F), relative humidity 80% (at 35°C) no condensation
Accessories	Power Adaptor,USB Cable,Transmittance Fixture, USB Disk, Black Cavity, White Tile, Green Tile,0% Calibration Cover, 30mm Aperture, 18 mm Aperture, 11 mm Aperture, 6 mm Aperture, Support, Sample Fixture
Optional Accessories	Transmittance Heating Fixture, Vertical Support, Pneumatic ram, Small Sample Fixture, Reflectance Glass Cell Support, Corrosion Resistant Support, Fiber Holder, Film Fixture,Transmittance Fixture for Small Aperture,Trolley Case,European Standard Plug,American Standard Plug、 Glass Cell

Interface	RS-232、USB、USB-B
Other	1. Camera to view test area clearly 2. Instrument can realize upward and downward measurement (need accessory) 3. Auto temperature and humidity compensation function

## Appearance and Structure

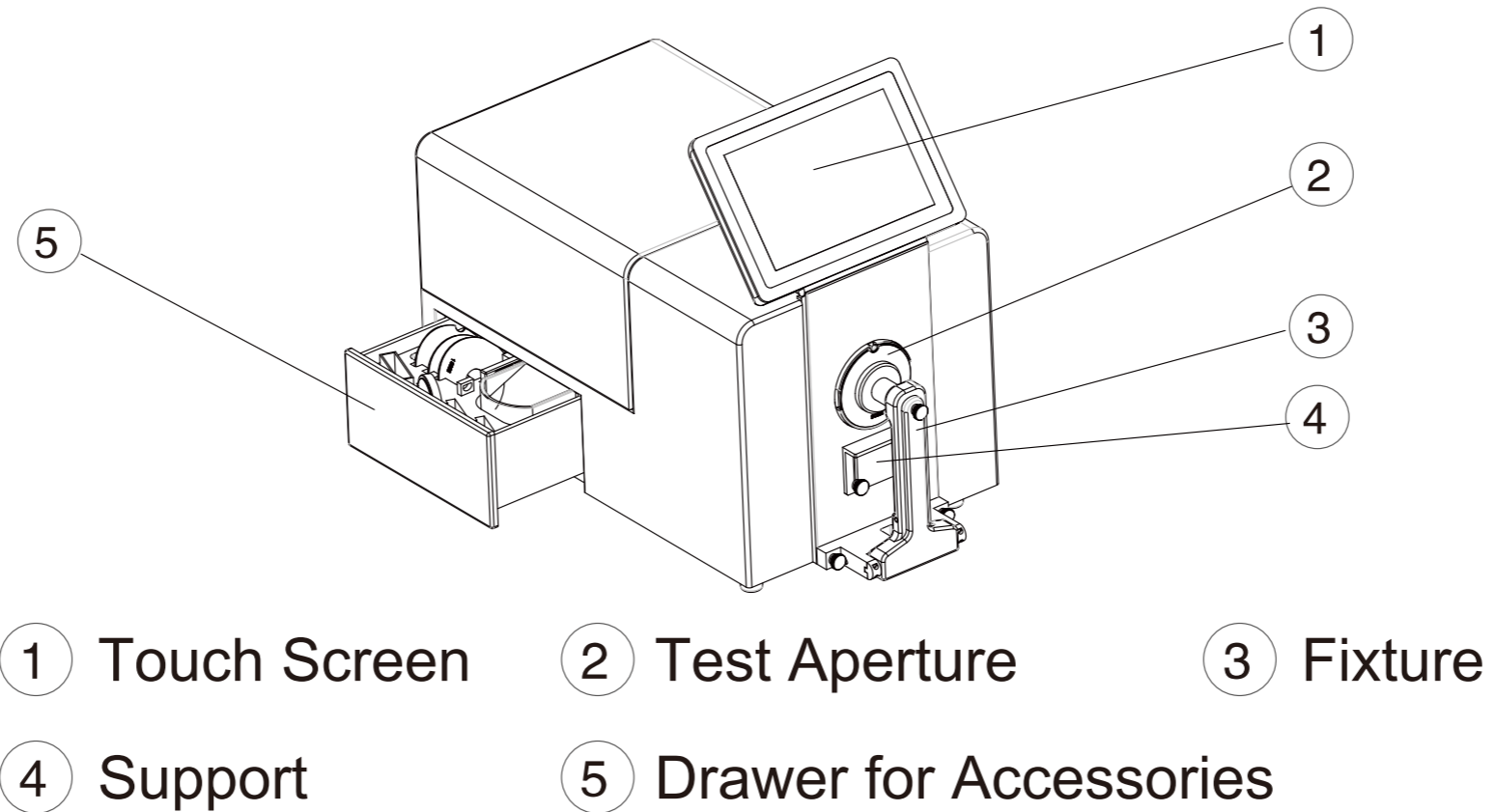

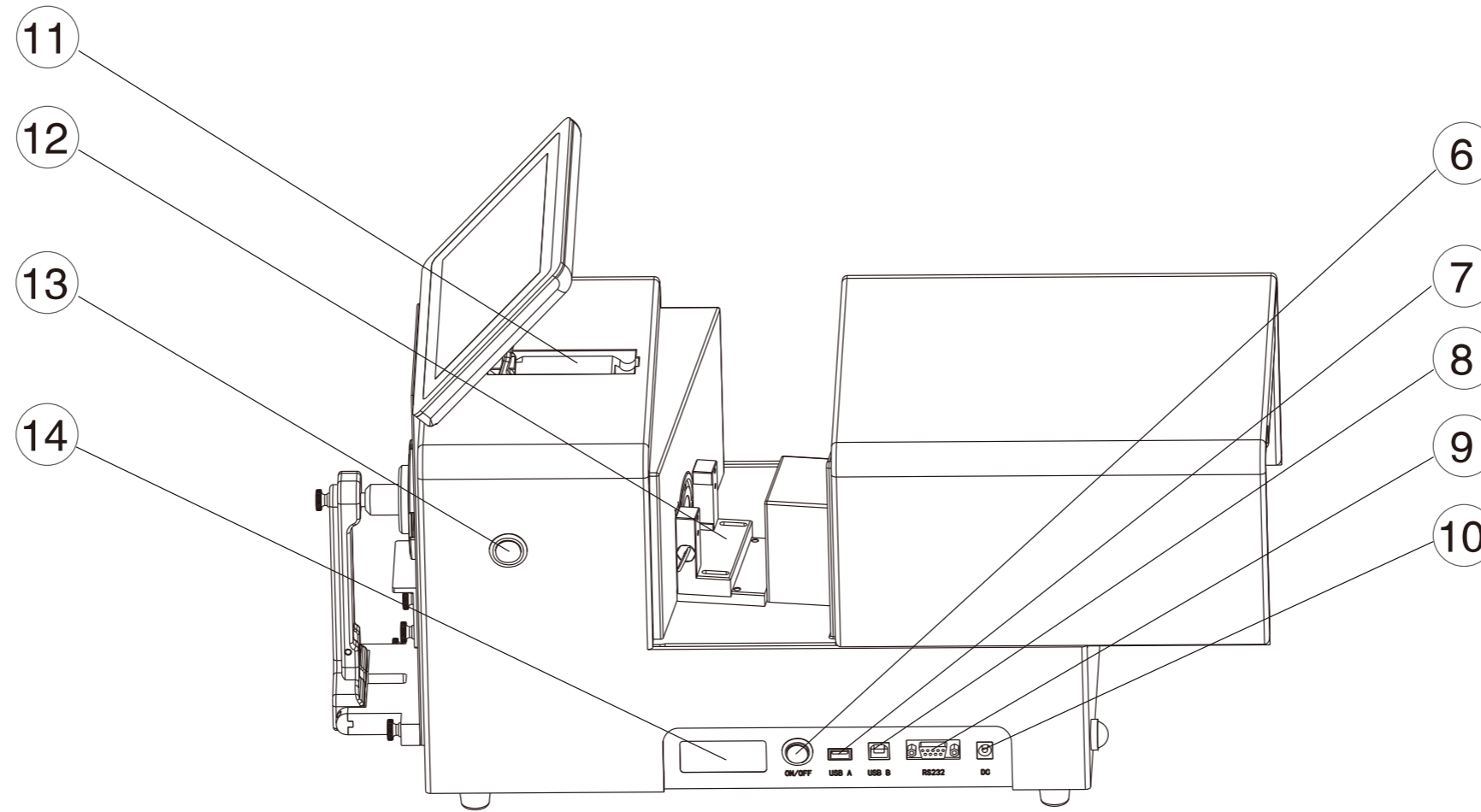

- ⑥ Switch on-off      ⑦ USB-A      ⑧ USB-B      ⑨ RS-232
- ⑩ Power Outlet      ⑪ Screen Anti-shake Bracket
- ⑫ Transmittance Fixture      ⑬ Test      ⑭ Nameplate

⑮ Top Cover Slide lock

⑯ Manual Damper

⑰ Bench

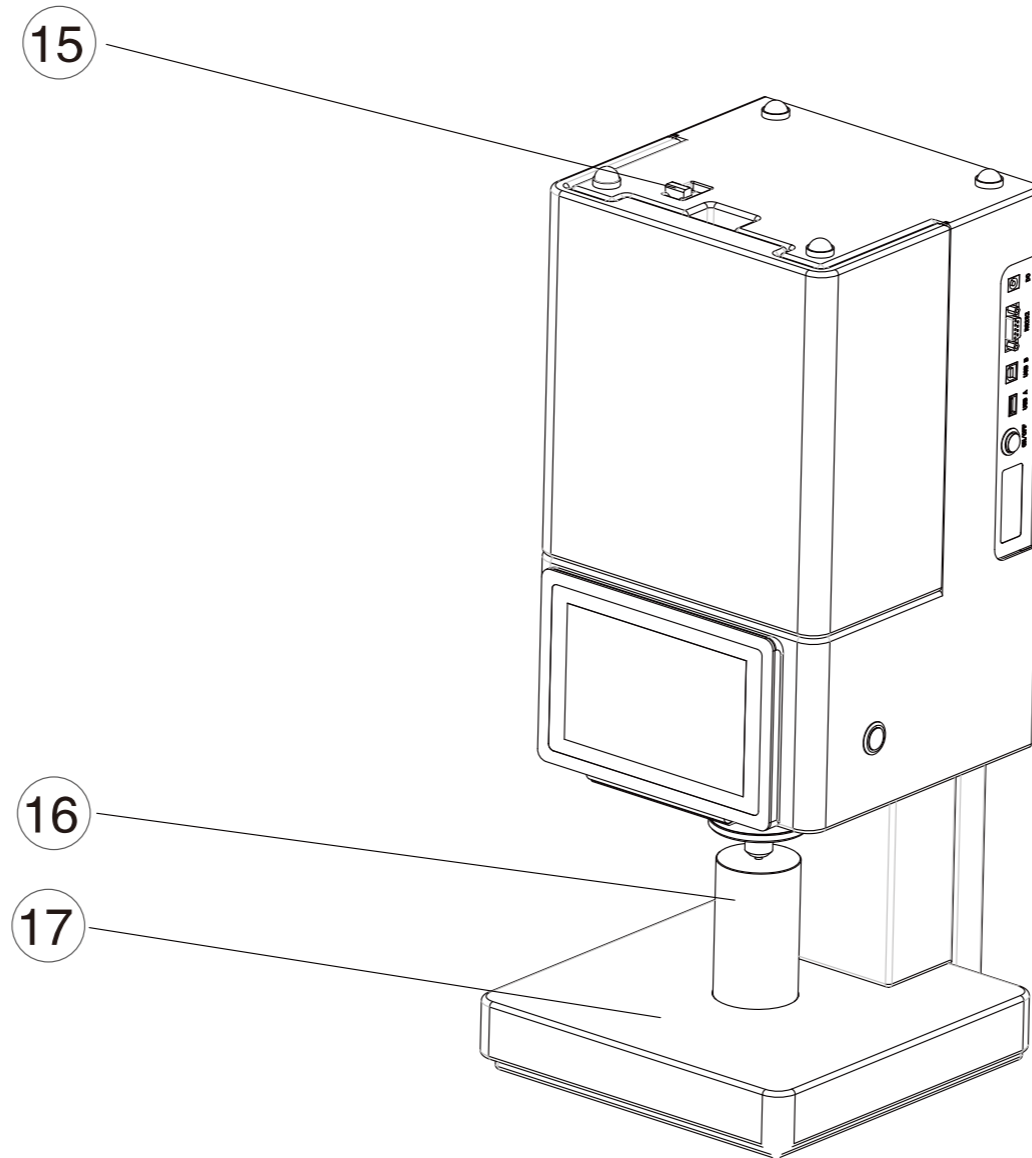

# Measurement Flow Chart

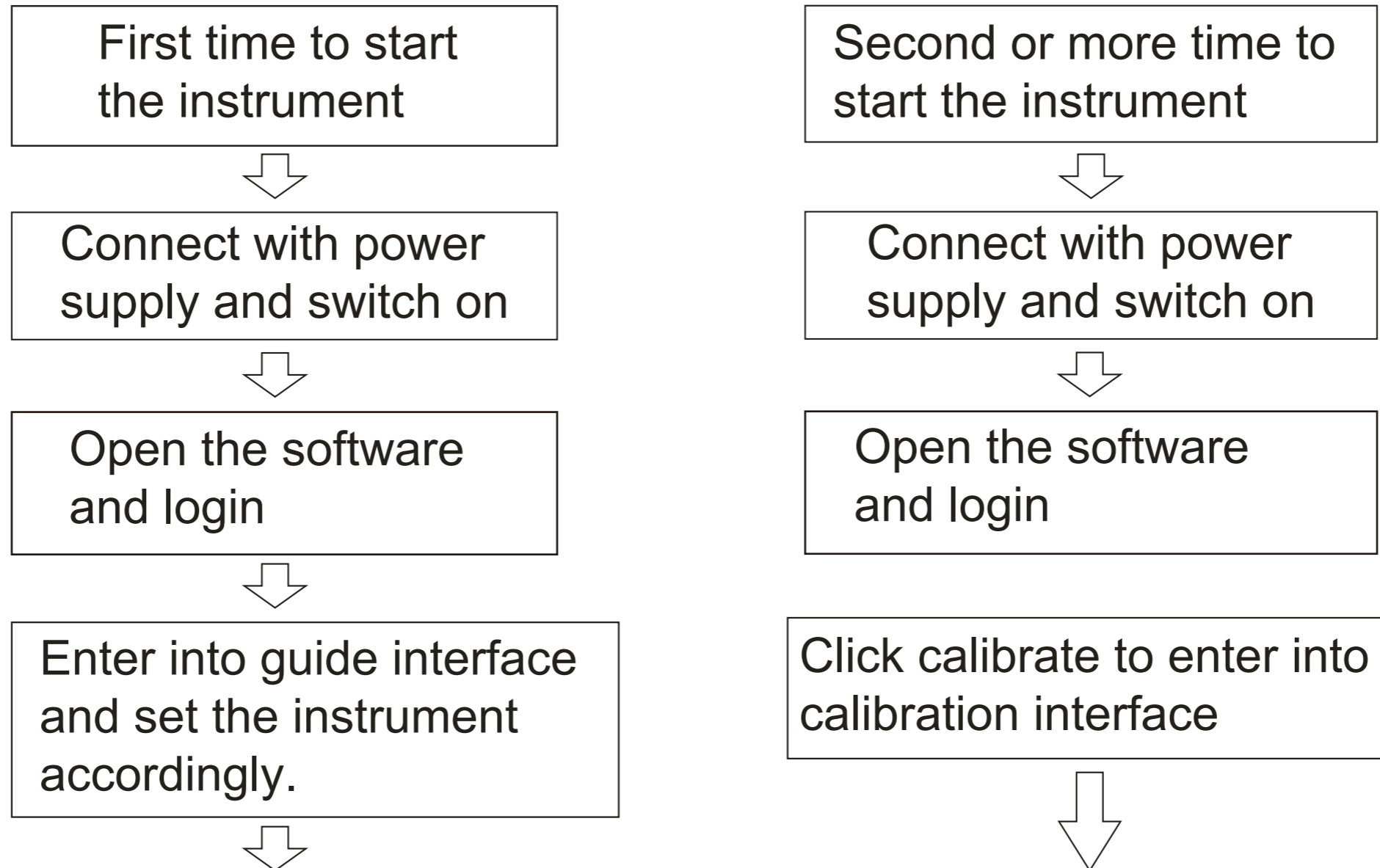

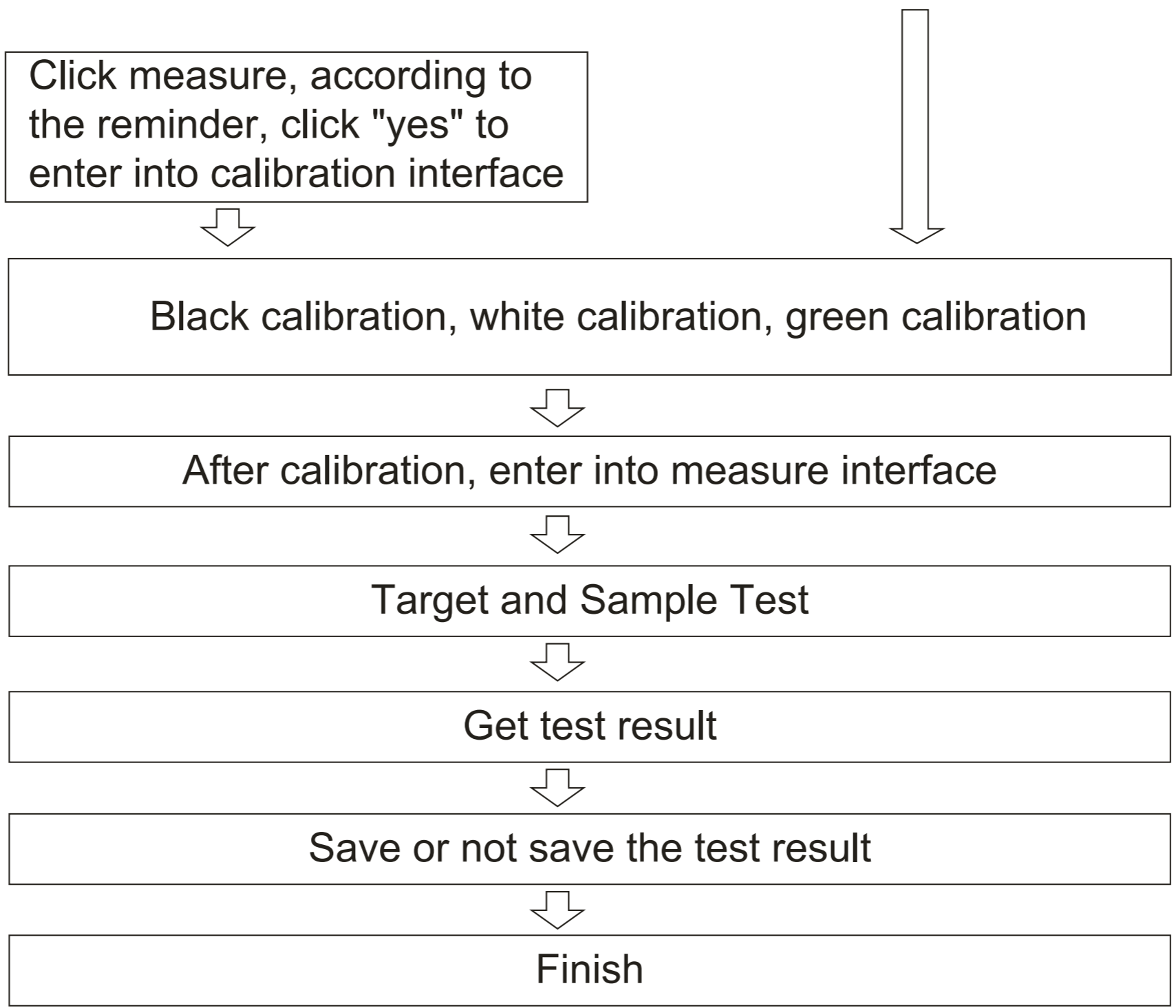

# Software Interface Introduction

## [Function Introduction]

**A-1**

### **Main Interface**

The software consists of 9 modules measure,setting,data view,my color,individual center,about,daily record and update,calibrate.

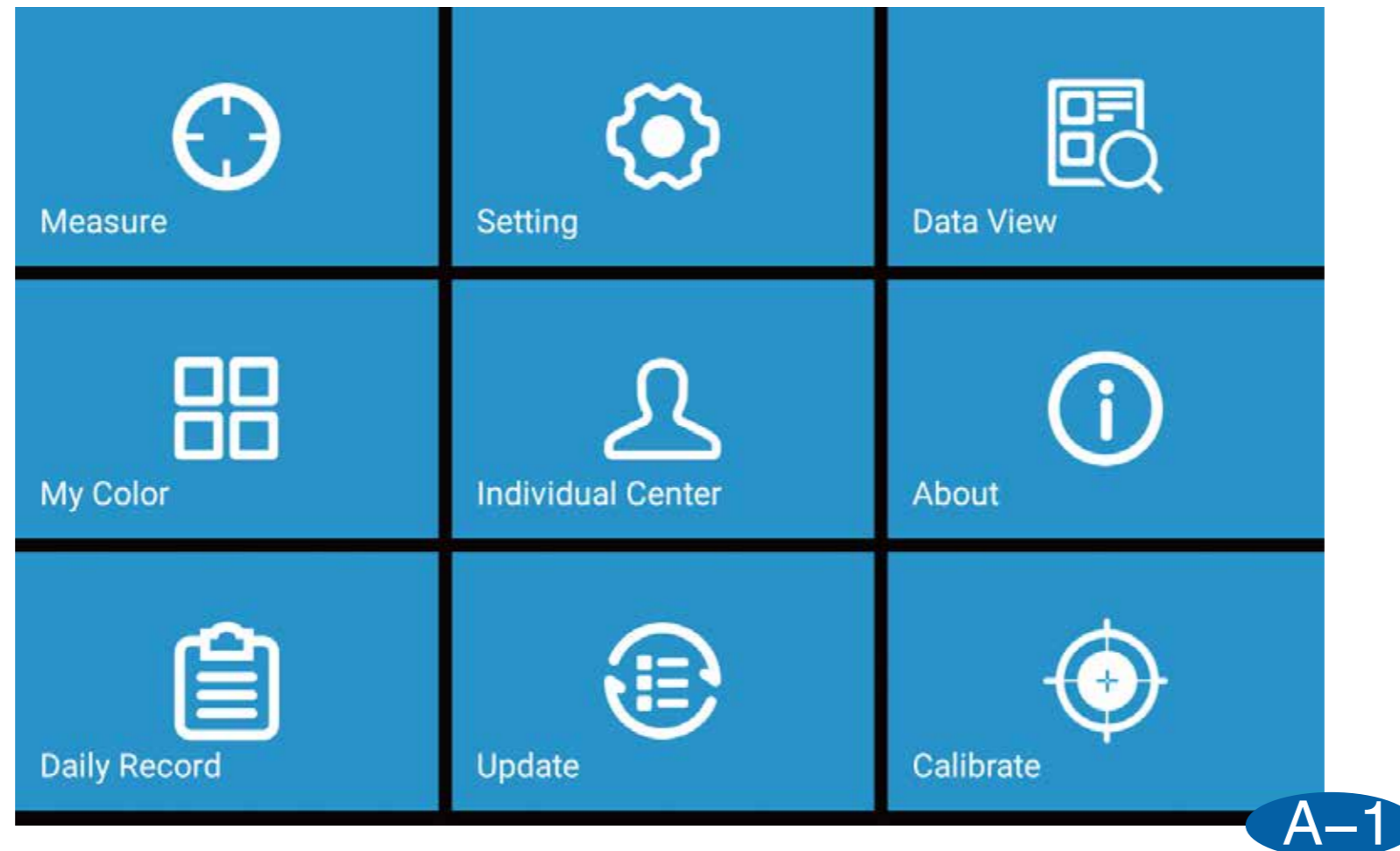

A-2

### Title Bar

Title bar from left to right are home icon,current page remind,illuminate/angle, SCI/SCE mode, reflectance/transmittance mode,UV condition,aperture,instrument temperature and instrument humidity.

Home button, click to return to home page

Display the current interface

Illuminate/angle

Current test mode

Instrument measurement mode

UV condition

Sensor temperature and humidity

Aperture

Test Target --- Target0013

Standard data name

Test Sample --- Sample0001

Sample data name

Target	Sample	
L* = 63.64	L* = 65.97	dL* = 2.33 White
a* = -0.08	a* = 10.52	da* = 10.60 Red
b* = 1.53	b* = 16.52	db* = 14.99 Yellow
c* = 1.53	c* = 19.58	dc* = 18.05 Fail
h = 93.12	h = 57.52	dH* = -3.35 Fail
		dE*ab
		18.51 Fail

Turn on the camera and display the graph of the measuring aperture area

Click to enter the setting interface

Click Export Report

Click to save current data

Click to measure

A-2

# [Software Login]

Login is divided into local login and network login. Enter the account number and password, the instrument will automatically identify the account type. Tick the remember password and it can realize automatically entered the next time. When you turn on the instrument next time, you will enter the software directly.

**B-1**

## **Local Login**

Login in account is admin, pass word is the instrument serial number (after login, pass word can be revised in the individual center). If the instrument serial number is C81118C0128, the pass word will also be C81118C0128.

Language English

Wifi Setting

Login

Register

admin

...

Keep Password

Auto Login

Login

[《Instructions》](#)

[Forget Password?](#)

B-1

**B-2**

## Net Work Login

Network login needs to connect to the network, click register, after registration is completed, user can use the registered account to perform login. Use the network login to upload the stored data to the cloud, and manage the data on the windows.

The screenshot shows a web interface for network login and registration. At the top, there is a dark header with a language dropdown menu set to 'English' and a 'Wifi Setting' button. Below the header, there are two tabs: 'Login' and 'Register', with the 'Register' tab selected. The main content area contains two columns of input fields. The left column includes fields for 'Account', 'Password', 'Confirm Password', and 'Mobile Number Or Email'. The right column includes fields for 'Company Name', 'Address', and 'Name'. At the bottom, there are three buttons: 'Input Code', 'Get Code', and 'Register'. The 'Get Code' and 'Register' buttons are highlighted in blue.

**B-2**

# [Guide]

## C

First time login or login after factory reset, instrument will enter into guide interface, we can set the instrument accordingly.

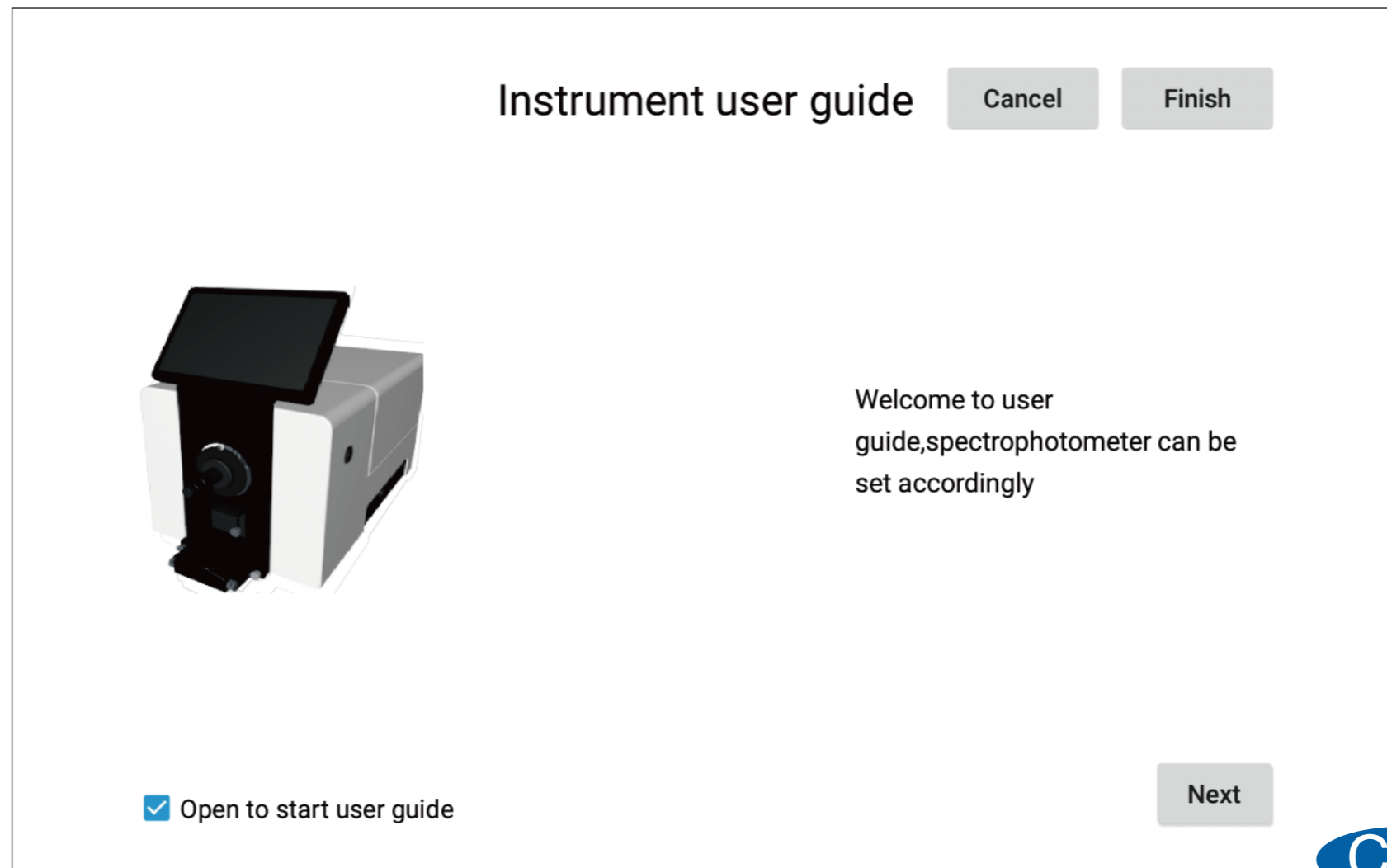

# Mode Selection

CANCEL

Finish



1/6

Previous

Next

C-2

## Instrument Setting

CANCEL

Finish

### Test Mode

SCI

SCE

SCI+SCE

### UV Setting

UV400 Cut

UV420 Cut

UV460 Cut

UV Include

### Aperture Setting

Auto Recognition

Customize  mm

Ignore Aperture Error

2/6

Previous

Next

C-3

# Parameter Setting

CANCEL

FINISH

**Illuminant&Angle** (The second illuminant is for calculating the metamerism)

First

Second

**CMC(l:c)**

l  c

**CIE94**

KL  KC  KH

**CIE 2000**

KL  KC  KH

3/6

Previous

Next

C-4

# Tolerance Setting

CANCEL

Finish

CIE LAB&LCH Hunter Lab CIEDE2000 CIE LUV CMC(l:c)&CIE94 Liquid Haze Temperature & humidity Parameter ada

## CIE LAB

		Upper Limit	Lower Limit	Between
dL*	± 2.0	White	Black	Pass
da*	± 2.0	Red	Green	Pass
db*	± 2.0	Yellow	Blue	Pass
dE*ab	2.0	Fail		Pass

## CIE LCH

dC*	2.0	dH*	2.0
-----	-----	-----	-----

4/6

Previous

Next

C-5

## Other Settings

CANCEL

Finish

### Average

Single Test     Average Test

### Save Setting

Manual Save     Auto Save

### Naming Rules

Target        +     Number    +     Date

Sample        +     Number    +     Date

### Heating Die Setting

Enable Heating Fixture

TargetTem...

CurrentTe... 0.00°C

5/6

Previous

Next

C-6

# Display Setting

CANCEL

**Color Diff.**

- Data
- Figure
- Haze (transmission)
- Opacity
- Metamerism
- Liquid chromaticity
- Find Similar Color
- Masterbatch

**CIELABCH**

- CIEDE2000
- CIE94
- CMC
- Hunter Lab

Measure D65/10° SCI Reflectance UV Include Φ 11 34.2°C 56.7%RH

Test Target -- Target0001 Test Sample -- Sample0001

Target	Sample	
L* = 65.47	L* = 65.47	dL* = 0.00 Pass
a* = -14.46	a* = -14.46	da* = 0.00 Pass
b* = -23.02	b* = -23.02	db* = 0.00 Pass
c* = 27.18	c* = 27.18	dc* = 0.00 Pass
h = 237.87	h = 237.87	dH* = 0.00 Pass
		dE*ab 0.00 Pass

Camera  
Setting  
Save  
Measure

6/6

Previous

Finish

C-7

# [Calibrate]

## D-1

### Black and White Calibration

When the instrument is in reflectance mode, user need do white and black calibration according to the software remind. Calibration valid time, temperature and humidity can be set in this page.

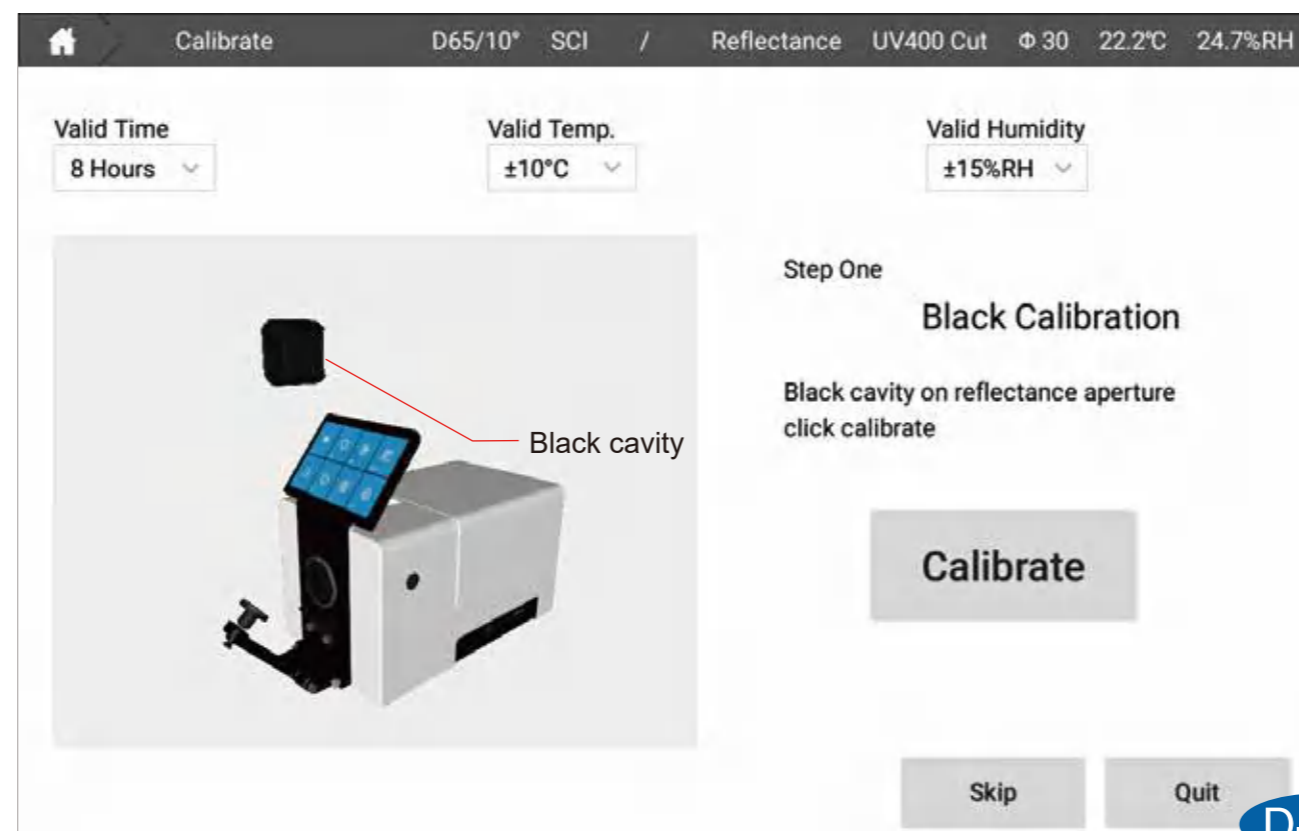



Calibrate

D65/10° SCI /

Reflectance

UV400 Cut

Φ 30

22.2°C

24.9%RH

Valid Time

8 Hours

Valid Temp.

±10°C

Valid Humidity

±15%RH



Step Two

## White Calibration

White tile on reflectance aperture  
click calibrate

**Calibrate**

Back

Skip

Quit

D-1/2

# D-2

## Green Calibration

After black and white calibration, software will remind for Green Check.

Green Check is used for verify the test result, it can be skipped.

Instrument software is with green tile value and user can also set the green tile value from green tile setting interface.

Note: Green calibration needs to be done in UV400 cut-off mode.

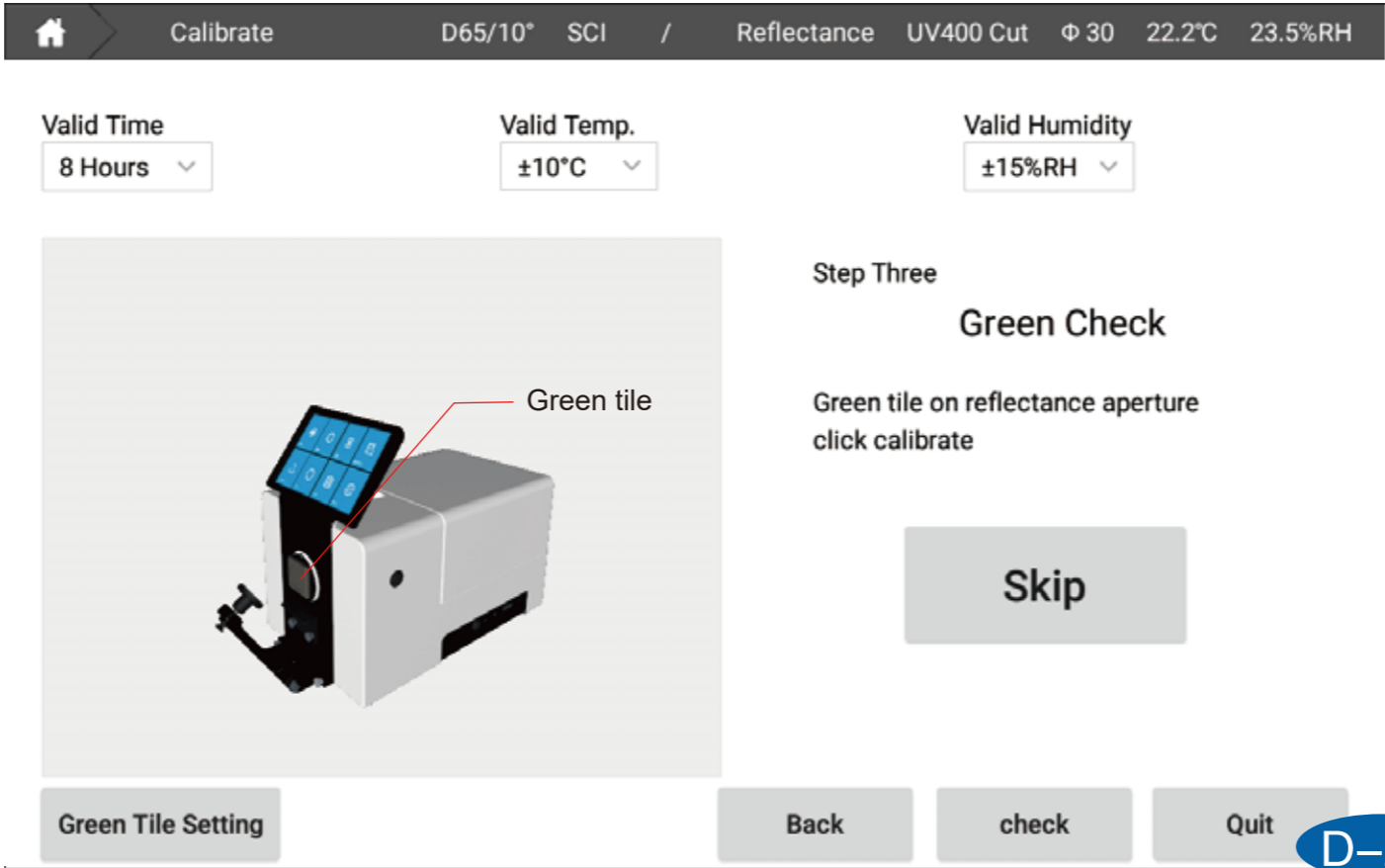

Calibrate D65/10° SCI / Reflectance UV400 Cut  $\Phi$  30 22.2°C 23.5%RH

Valid Time  
8 Hours

### Green Tile Setting

Use Test Value     Use Input Value

**Test Green Tile**

	L*	a*	b*
Test	58.83	-11.54	5.42

**Input Green Tile Value**

L*	a*	b*
0.00	0.00	0.00

**DE Value**

DE*	0.50
-----	------

Finish

Green Tile Setting    Back    check    Quit

# [Measure]

There are 3 measure modes target test, sample test and other test mode (opacity, find similar color).

**E-1**

## Target Test

In the main interface, click measure to enter into target measurement interface, after placed the sample, click measure on right bottom or press "test" button on instrument, test result will show on screen.

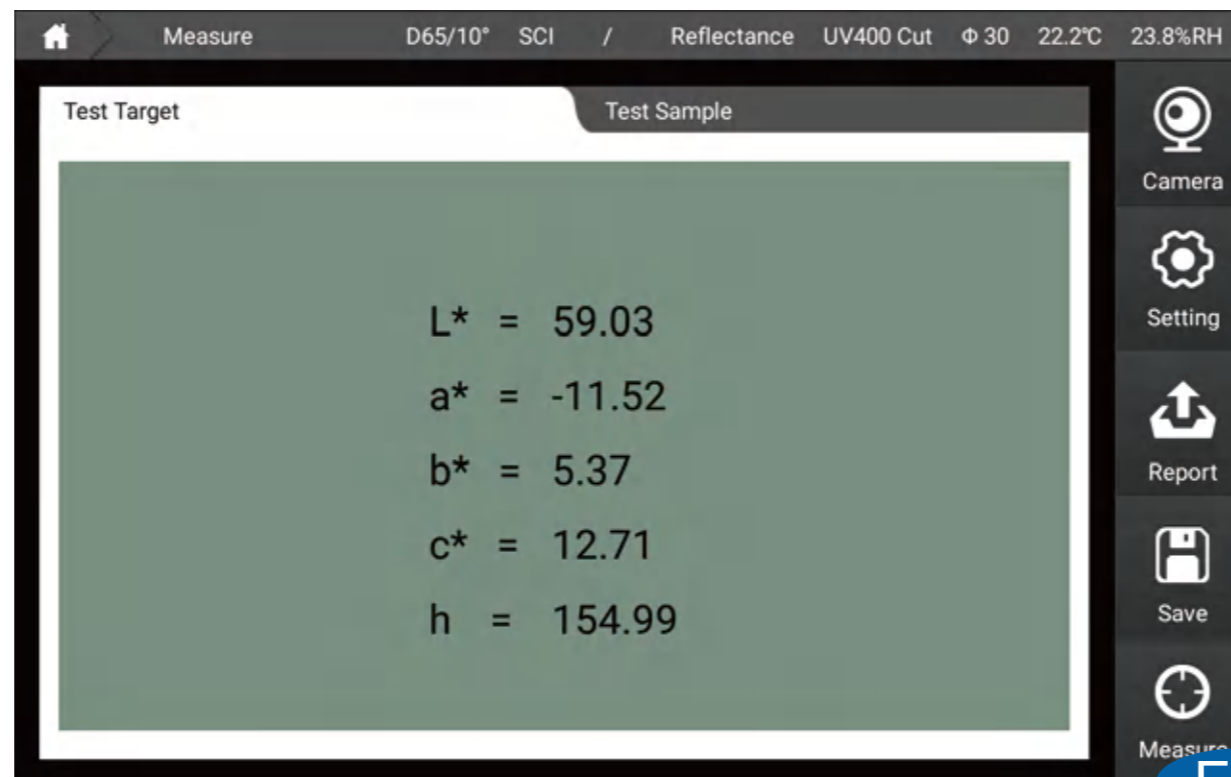

**E-1**

# E-2

## Sample Test

In target test interface, click sample to enter into sample measurement interface. After the sample is placed on the measurement aperture, click measure on the right bottom or press "test" button for sample measurement.

The screenshot shows a software interface for color measurement. At the top, it displays 'Measure' and various settings: 'D65/10° SCI / Reflectance UV400 Cut Φ 30 22.3°C 23.9%RH'. Below this, there are two tabs: 'Test Target' and 'Test Sample --- Sample0001'. The main area is divided into three sections: 'Target', 'Sample', and a summary section. The 'Target' section lists: L\* = 59.03, a\* = -11.52, b\* = 5.37, c\* = 12.71, h = 154.99. The 'Sample' section lists: L\* = 58.54, a\* = -11.61, b\* = 5.66, c\* = 12.91, h = 154.03. The summary section shows difference metrics: dL\* = -0.48 (Pass), da\* = -0.09 (Pass), db\* = 0.28 (Pass), dc\* = 0.20 (Pass), dH\* = -0.21 (Pass). Below these is a box for 'dE\*ab' with the value '0.57Pass'. On the right side, there is a vertical sidebar with icons and labels: Camera, Setting, Report, Save, and Measure.

Target	Sample
L* = 59.03	L* = 58.54
a* = -11.52	a* = -11.61
b* = 5.37	b* = 5.66
c* = 12.71	c* = 12.91
h = 154.99	h = 154.03

dL* = -0.48	Pass
da* = -0.09	Pass
db* = 0.28	Pass
dc* = 0.20	Pass
dH* = -0.21	Pass

dE*ab
0.57Pass

# E-2

# [Setting]

From setting interface, user can set test mode, parameter, tolerance, instrument display, save method, name rules, average test, etc. After revise, click apply.



## Setting

1. In the Transflective window, select Reflect or Transmit to set the working mode of the instrument.
2. In the test mode window, select SCI or SCE or SCI+SCE to set the test mode of the instrument.
3. Under the UV setting window, you can set UV or UV400 cutoff, UV420 cutoff, and UV460 cutoff.
4. In the aperture setting window, if you select automatic recognition, you can automatically set the aperture configured by the factory at this time, and automatically switch the lens position; if you select custom, then enter a value within 4 to 30 in the custom window, and select ignore at the same time. If the caliber is wrong, you can use the built-in caliber measurement.

Fluorescence calibration, you can manually import or import LAB, whiteness, spectrum and other types of data from EXCEL for fluorescence calibration.

(1) Click Fluorescence Calibration, check and confirm the pop-up prompt, and select OK to perform fluorescence calibration.

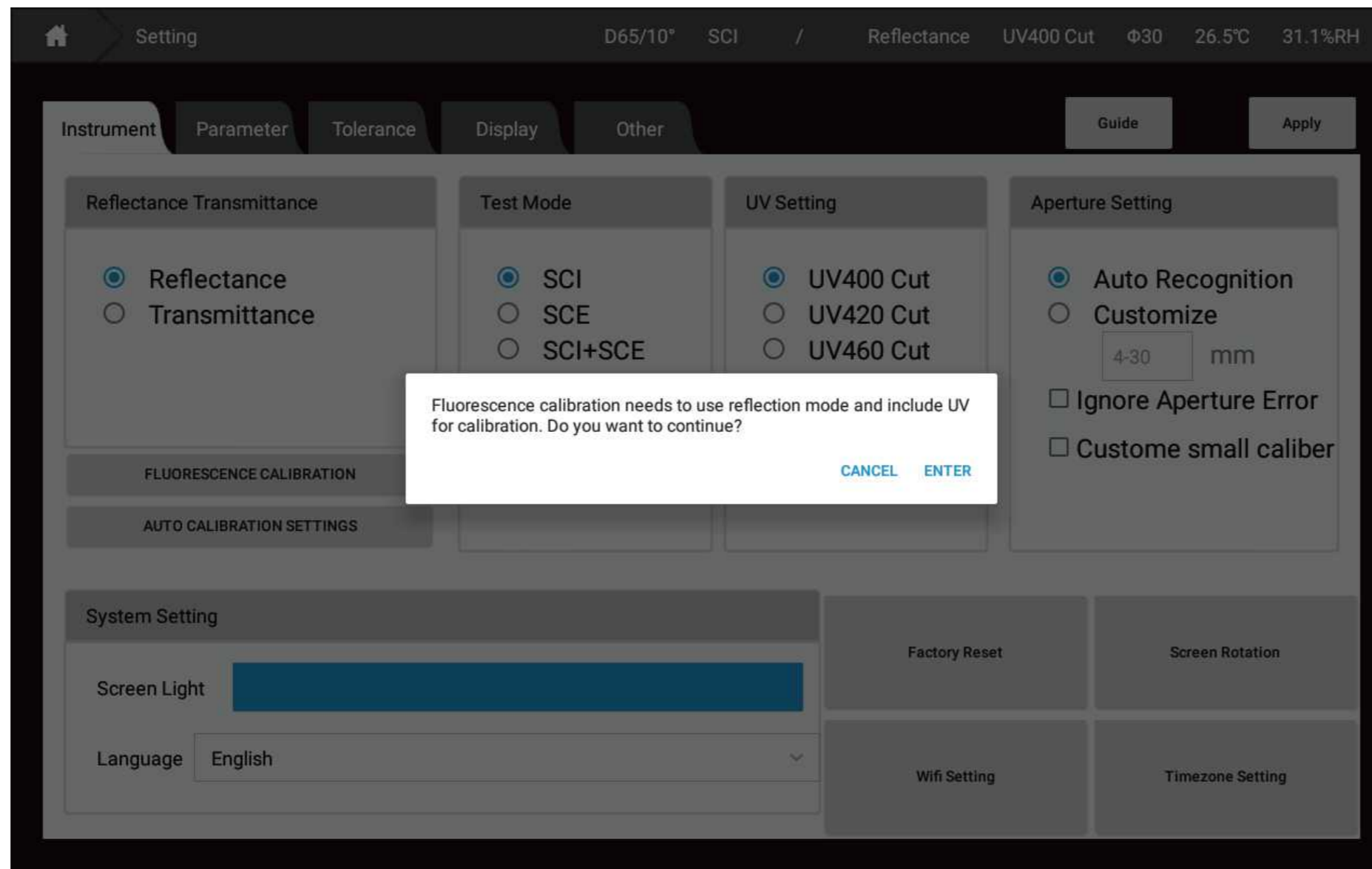

(2) Enter the fluorescence calibration interface, please follow the prompts to perform a black and white calibration, and the green calibration can be skipped.

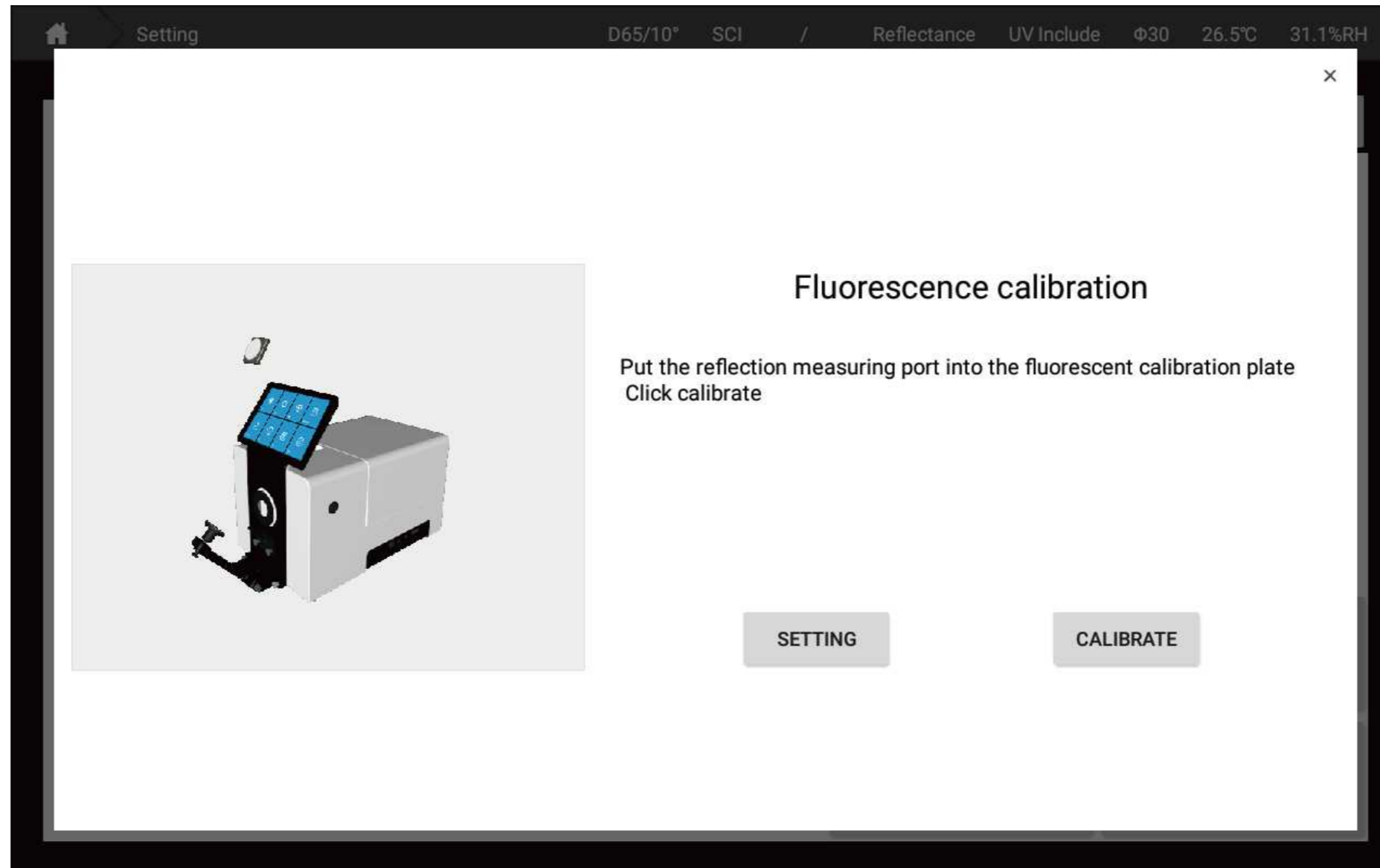

(3) After clicking Settings, the admin password will be requested. Defaults to the instrument's serial number (case sensitive).

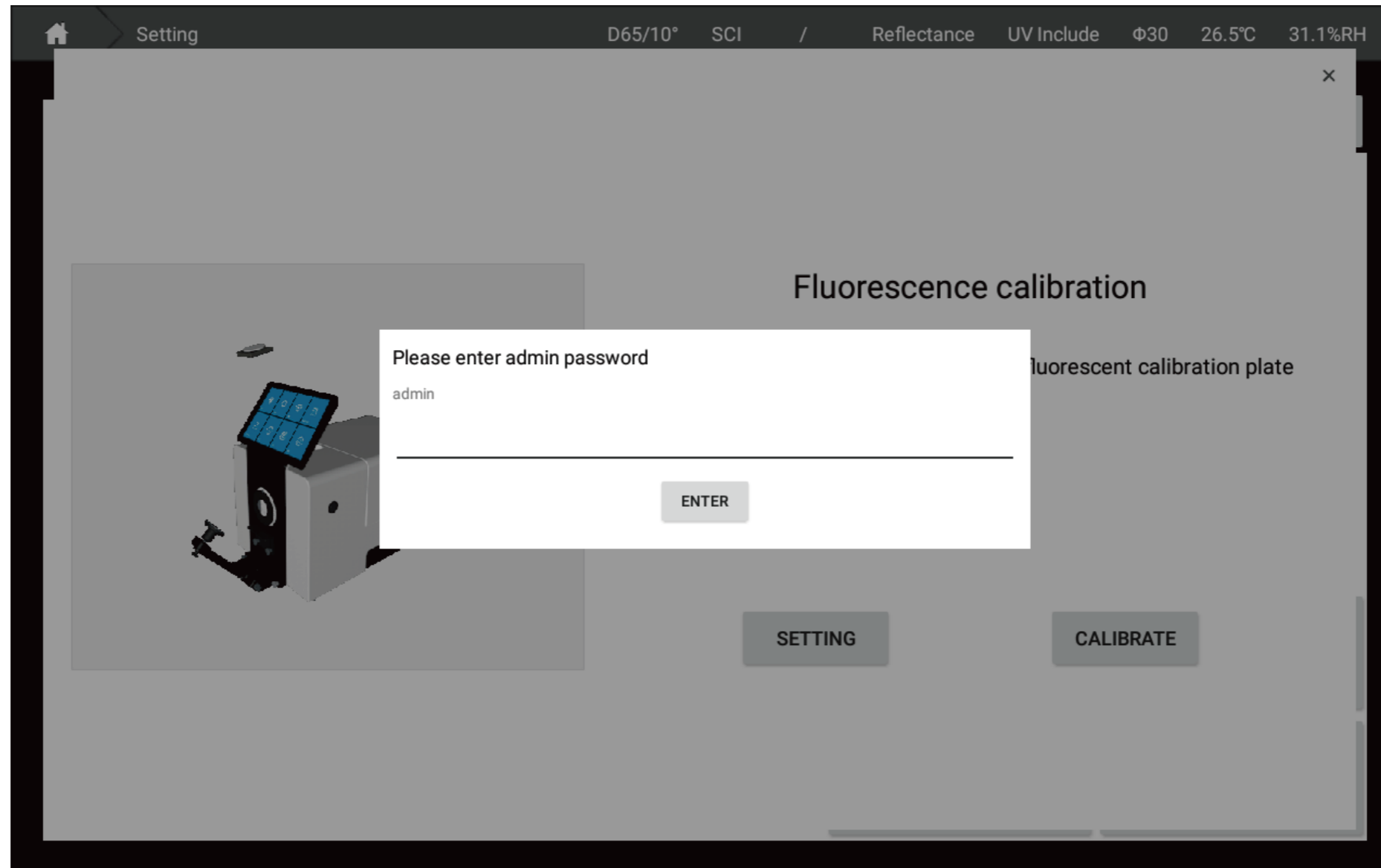

(4) After entering the admin password correctly, the fluorescence calibration setting can be performed. It can be imported manually or imported from EXCEL.

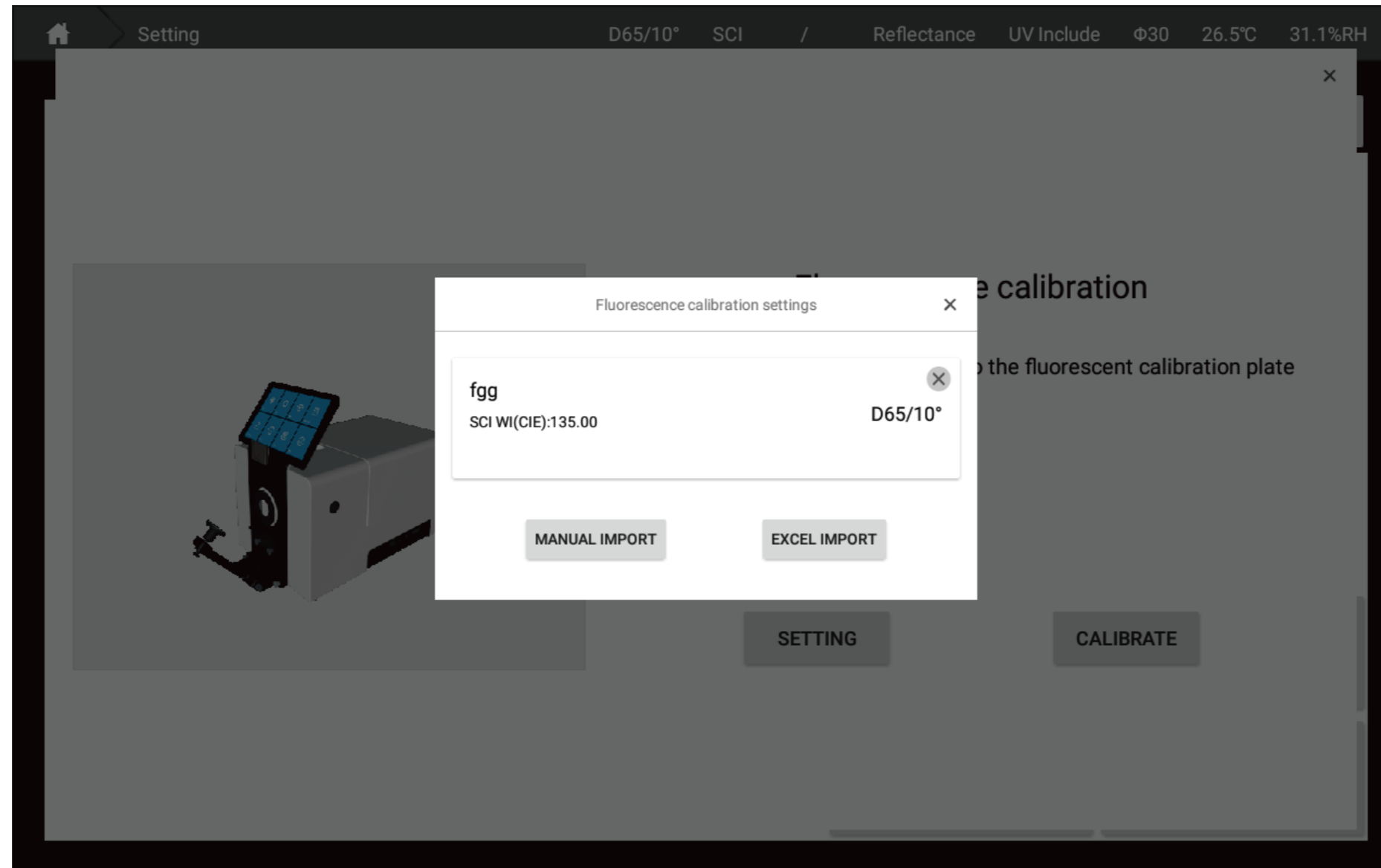

(5) Click Manual Import to automatically ask the imported data type.

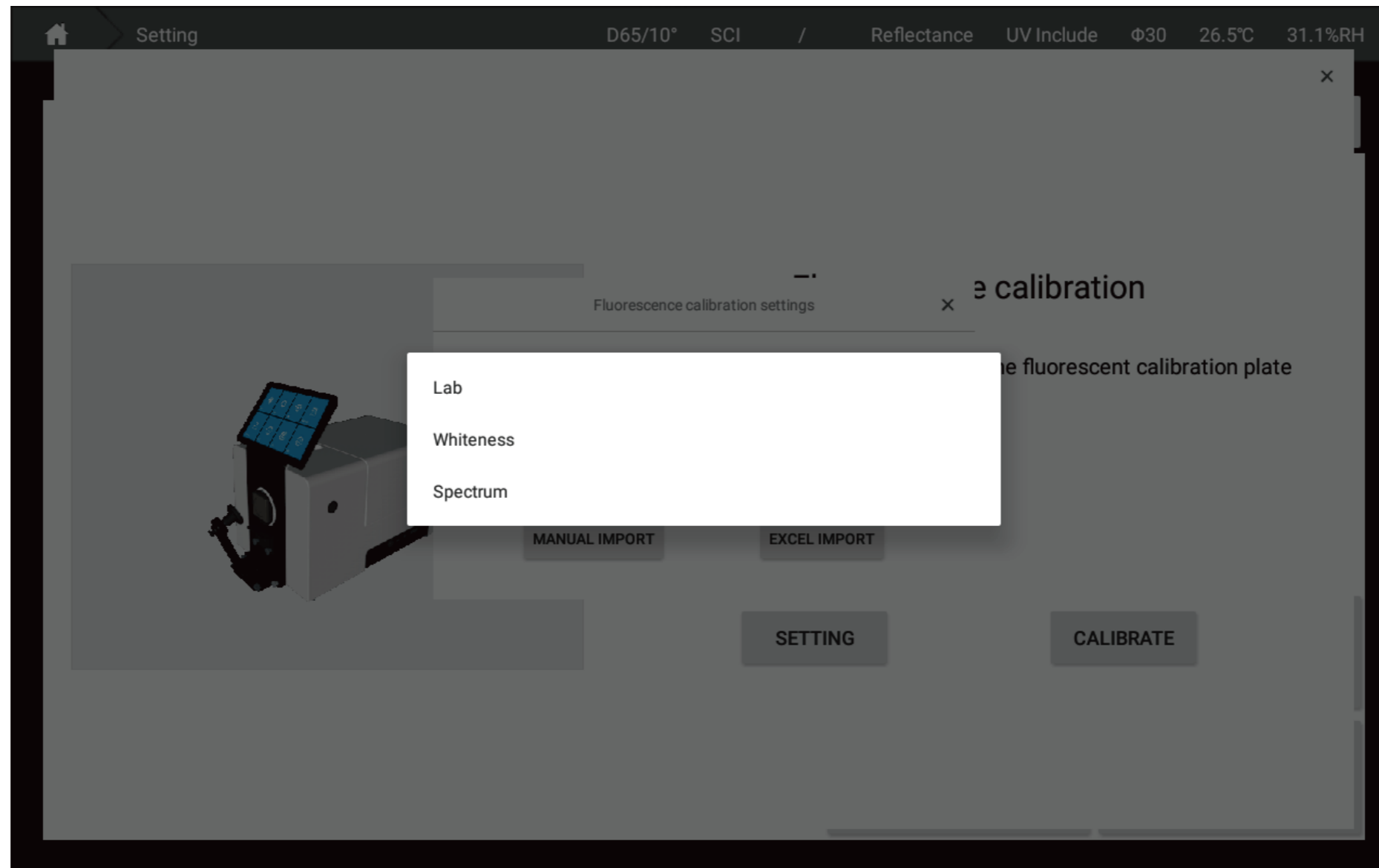

(6) Lab import. You can customize the name of the imported data. After selecting SCI or SCE, you can input the L\*, a\*, b\* values of the corresponding mode.

Setting D65/10° SCI / Reflectance UV Include Φ30 26.5°C 31.1%RH

Lab x

Name

SCI(D65/10°)  SCE(D65/10°)

L\*:  L\*:

a\*:  a\*:

b\*:  b\*:

FINISH

(7) Import of whiteness. You can customize the name of the imported data. Select the imported whiteness type (CIE, Hunter, etc.). After selecting SCI or SCE, you can enter the whiteness value of the corresponding mode.

The screenshot shows a software interface with a 'Setting' menu at the top. The main display area shows 'D65/10° SCI / Reflectance UV Include Φ30 26.5°C 31.1%RH'. A 'Whiteness' dialog box is open in the center, featuring the following elements:

- Name:** An empty text input field.
- Whiteness type:** A dropdown menu currently showing 'WI(R457/ISO2470)(...)'.
- Mode Selection:** Two radio buttons, with 'SCI' selected and 'SCE' unselected.
- Whiteness Values:** Two empty text input fields, one for each mode.
- FINISH:** A button at the bottom center of the dialog.

(8) Spectral import. You can customize the name of the imported data. After selecting SCI or SCE, you can enter the reflectance values under different wavelengths of the corresponding mode.

The screenshot shows a software interface with a 'Spectrum' dialog box. The background shows a 'Setting' menu and various parameters: D65/10°, SCI, Reflectance, UV Include, Φ30, 26.5°C, and 31.1%RH. The dialog box is titled 'Spectrum' and has a close button (X). It contains a 'Name' input field, a checked radio button for 'SCI', and an unchecked radio button for 'SCE'. Below these are two columns of input fields for wavelengths: 360nm, 370nm, 380nm, 390nm, 400nm, and 410nm. A 'FINISH' button is located at the bottom of the dialog.

(9) EXCEL import. After selecting the EXCEL file to be imported, click Import to import directly.

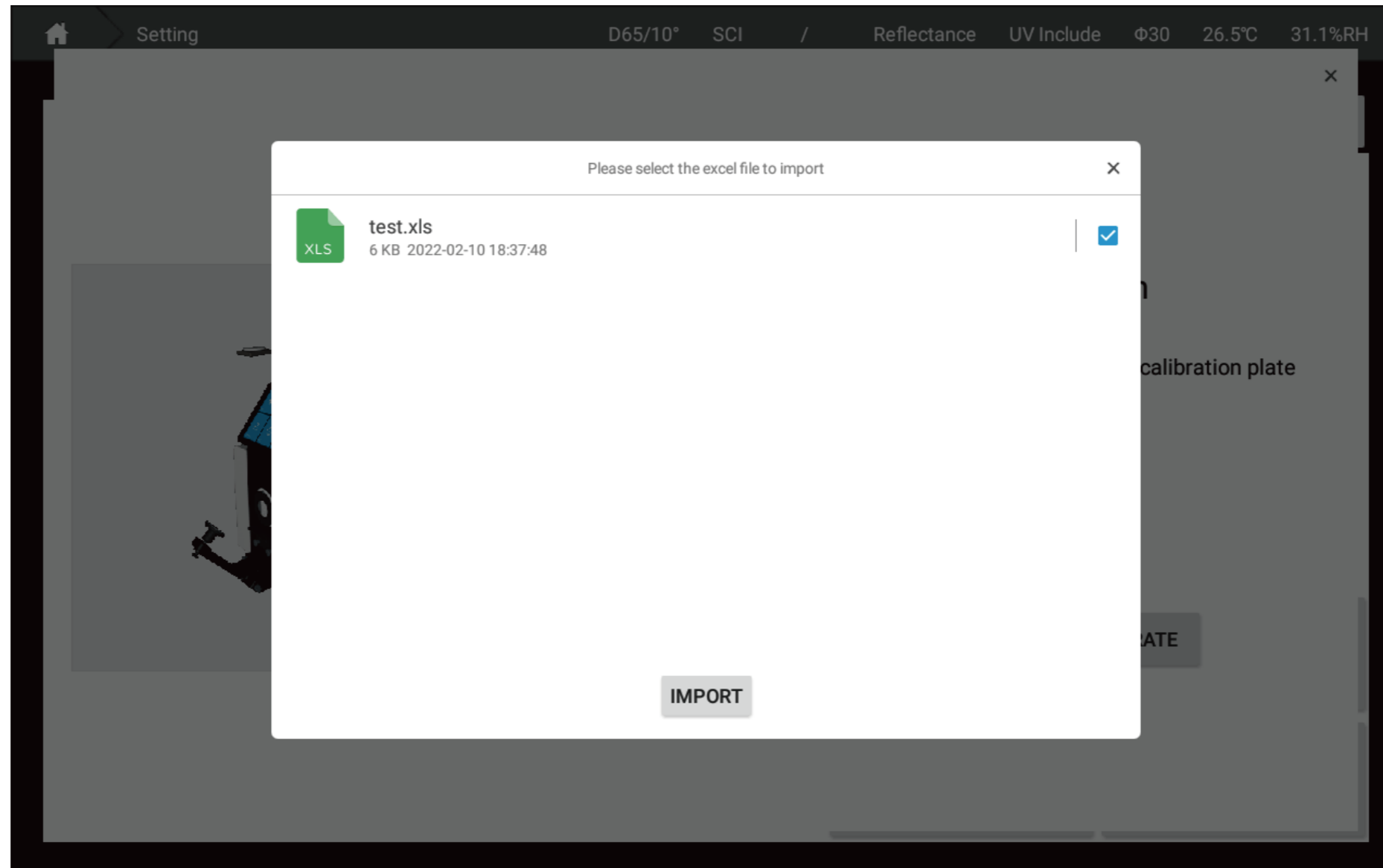

Auto calibration settings, you can customize the black and white calibration interval, and whether to enable automatic calibration and measurement calibration.

(1) Click Auto Calibration Settings, you can customize the black and white calibration interval, and choose whether to enable automatic calibration and measurement calibration.

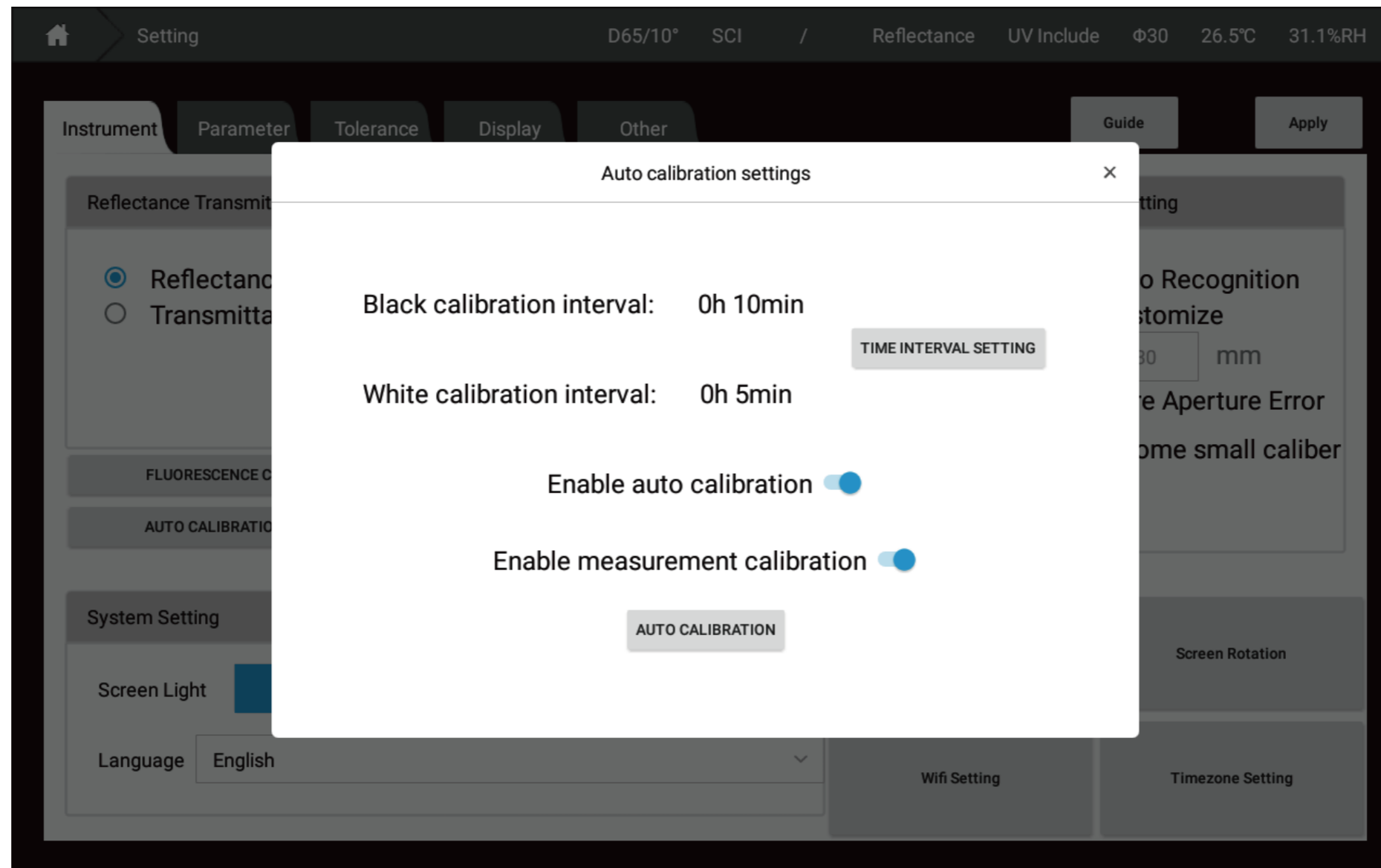

(3) Enable or disable automatic calibration, measurement calibration. After enabling automatic calibration, the instrument will automatically perform a black calibration and a white calibration after each power-on. After enabling measurement calibration, the instrument will periodically perform black calibration and white calibration during idle time during normal operation. When disabled, black and white calibration will not happen automatically at any time.

① The screen backlight and software display language can be set in the system setting window.

② Click restore to factory settings to restore the instrument to the factory settings.

③ Click the screen rotation button, the screen will rotate 180°.

④ Wifi settings, connect or manage available wireless networks.

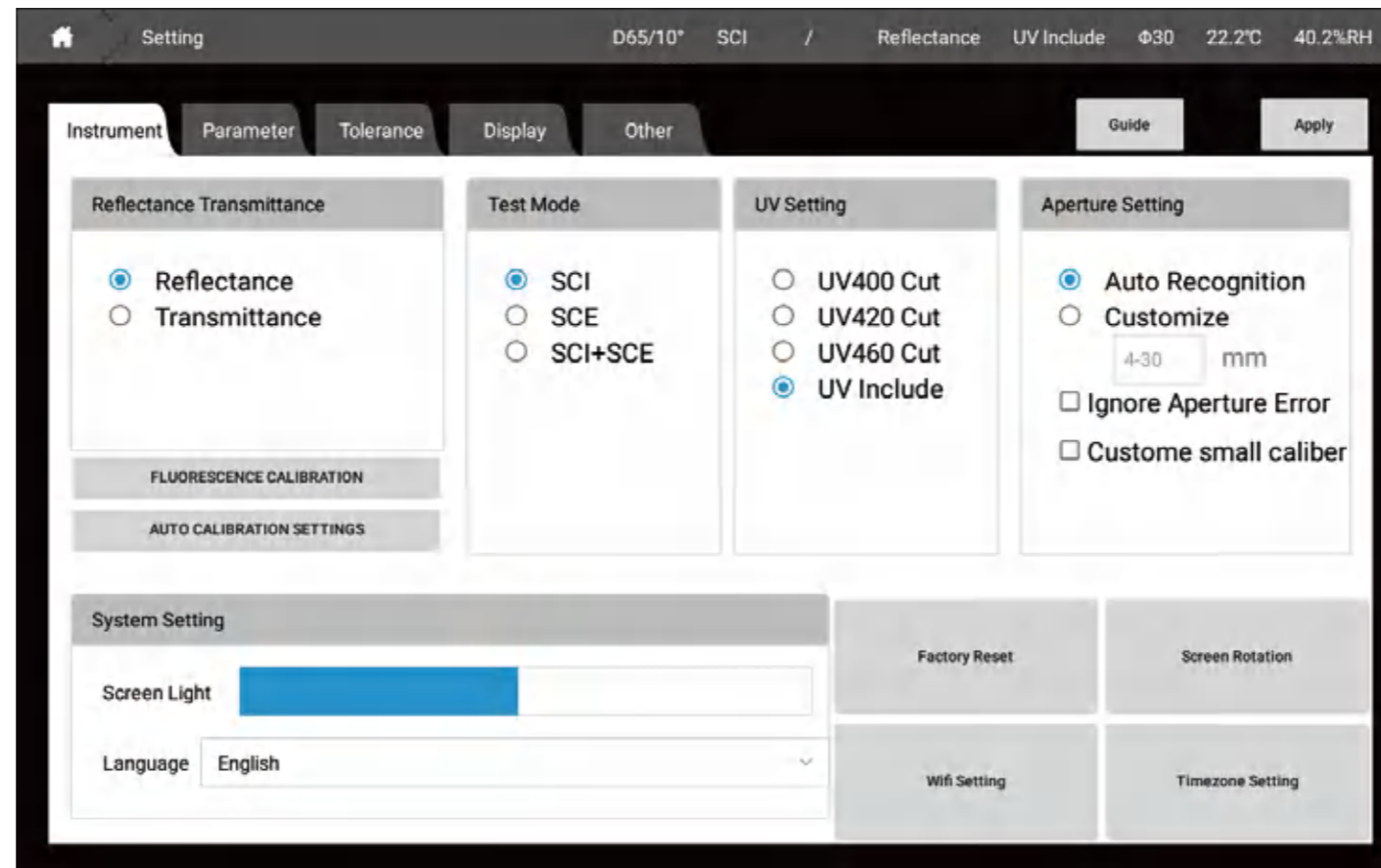

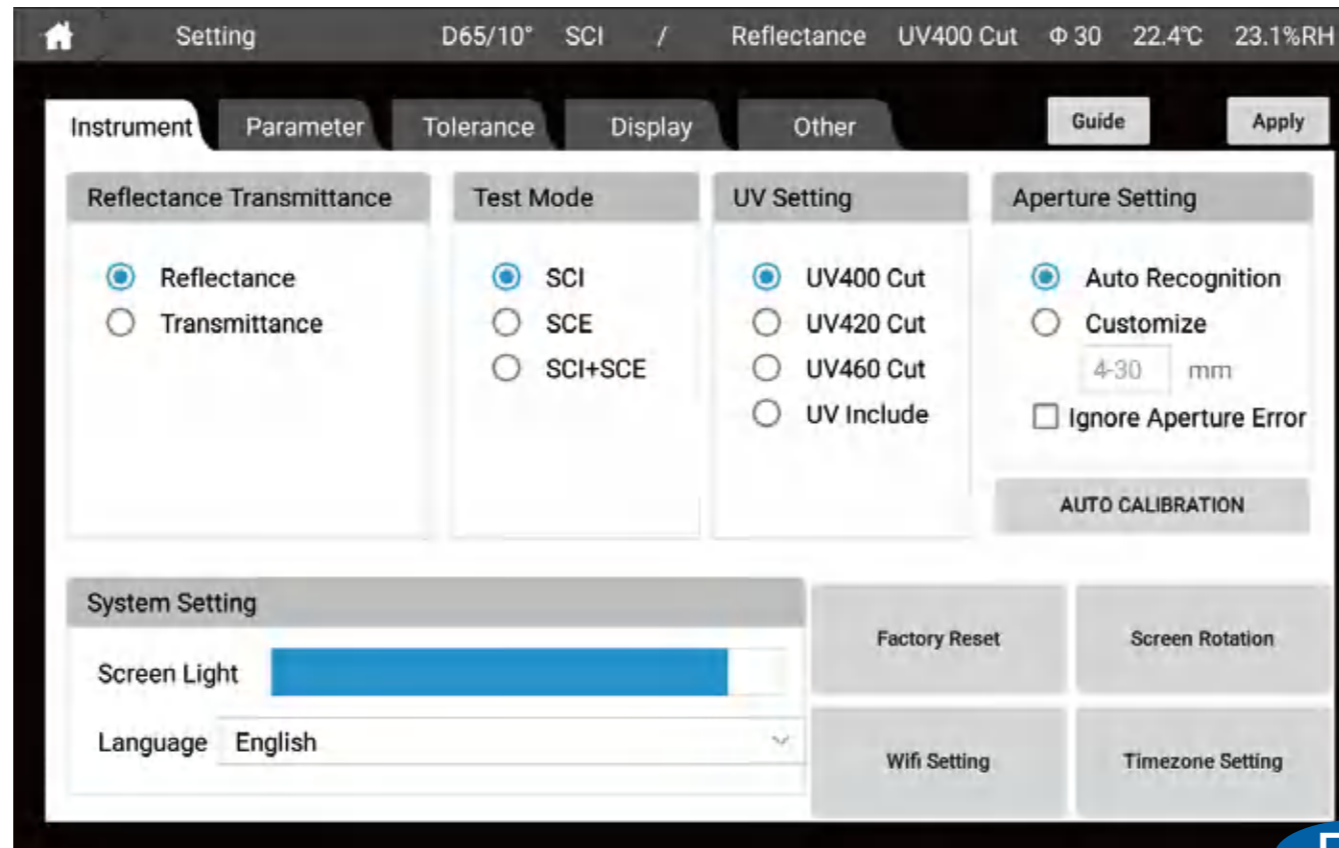

F-1

F-2

## Parameter Setting

Parameter setting, user can set the following parameters.

1. Illuminants & Angles : User can set illuminant and angle for calculating the test result. The first illuminant and angle is the calculation data for all modes. The second illuminant is for calculating metamerism. (Note: Find similar color and my color illuminant and angle is fixed D65/10°)

2.CMC(l:c):l and c value can be set

3.CIE94:The coefficient KL,KC and KH value of Color different formula CIE91 can be set.

4.CIE94:The coefficient KL,KC and KH value of Color different formula CIE2000 can be set.

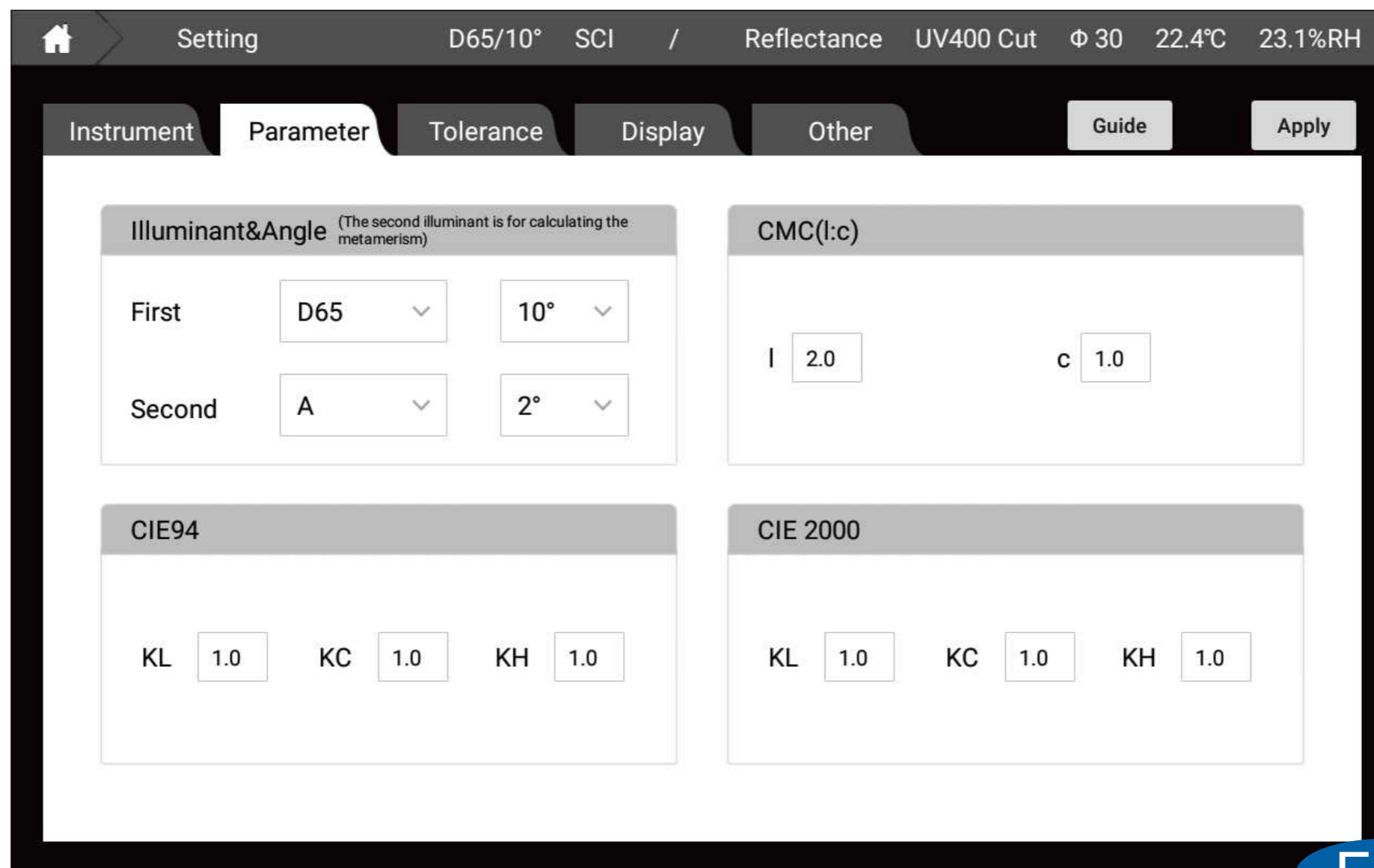

F-2

# F-3

## Tolerance Setting

Tolerance is for judging if the sample's color is pass or not comparing with target. When the difference value is larger than tolerance, it will show fail, when the difference value is smaller than tolerance, it will show pass.

We can choose different color difference formula and set tolerance. (CIE Lab page allow user to set the remind words)

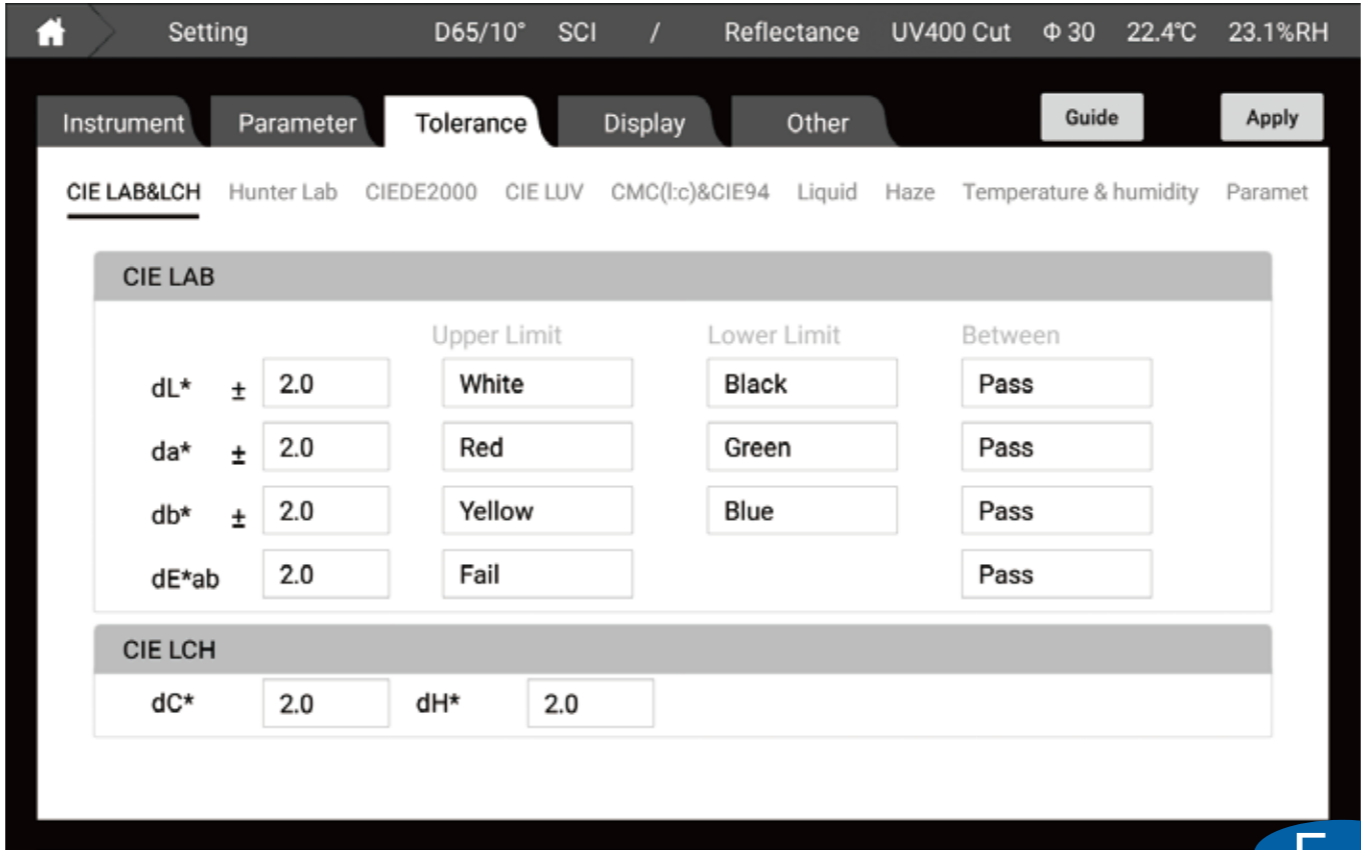

## F-4

### Display Setting

Display setting can set the content shows in measure interface. The following display can be set:

1. Color difference: CIE LABCH, CIE DE2000, CEI94, CMC, Hunter Lab
2. Data: It will show all parameters that the instrument can measure (expect haze and opacity)
3. Figure: CIE Lab, Yxy, Luv, reflectance/transmittance, K/S curve, absorbance curve.
4. Haze: measure the haze and total transmittance of transparent and translucent materials
5. Opacity: measure opacity
6. Metamerism: for measuring metamerism
7. Liquid chromaticity: Saybolt, ASTM color, Pt-Co, Gardner color
8. Find similar color: user can find similar color from "my color"
9. Color Master Batches: color test of color master batches
10. Titanium Dioxide: color test of color master batches
11. Paste: color test of pasty materials

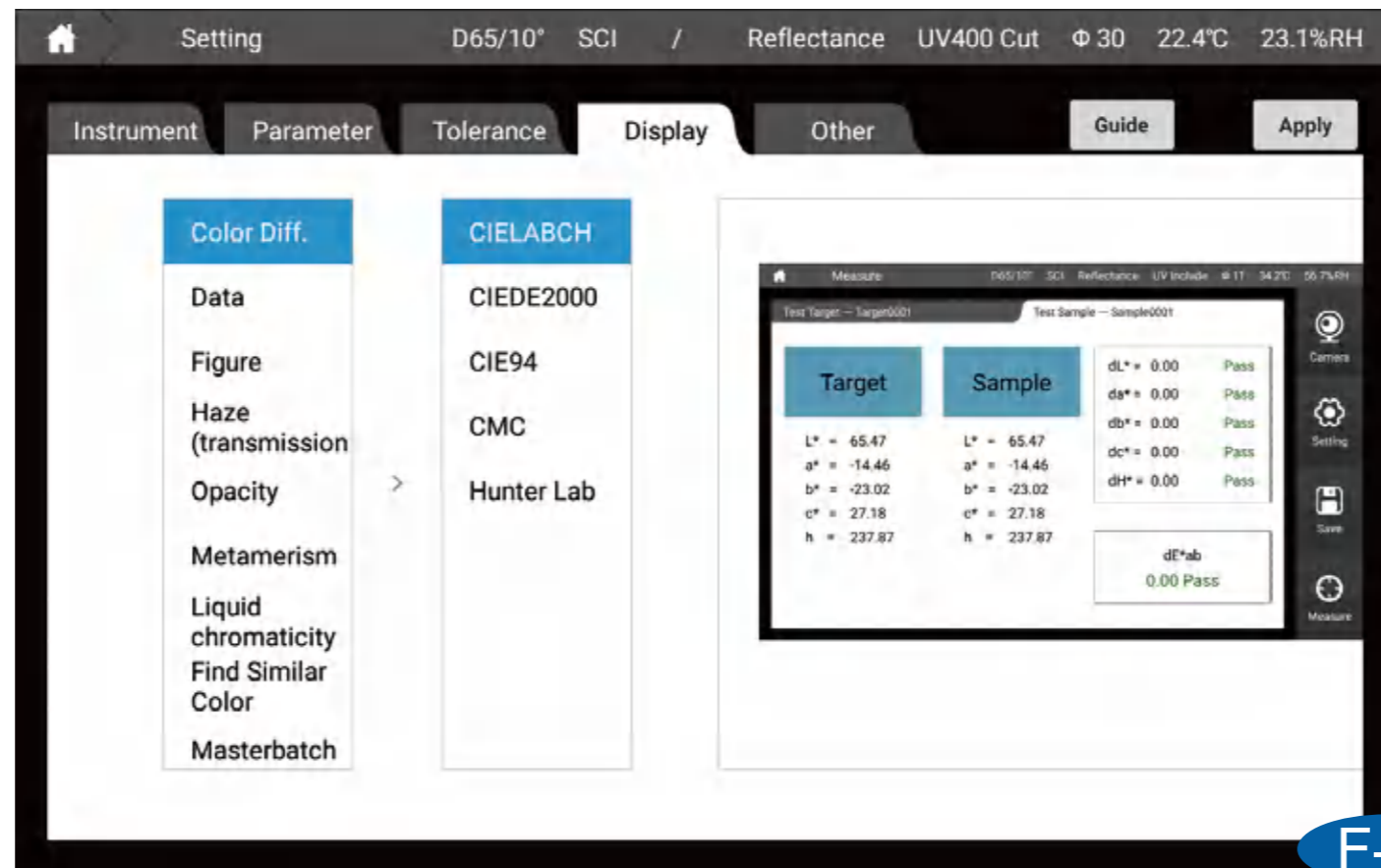

## F-5

### Other

1. Average setting : User can set single test or average test
2. Save Setting: User can set manual save or auto save
3. Naming Rules: User can choose the rules for naming the sample
4. Heating mold setting: User can start heating fixture and set the heating temperature.

Setting D65/10° SCI / Reflectance UV400 Cut Φ 30 22.4°C 23.1%RH

Instrument Parameter Tolerance Display **Other** Guide Apply

**Average**

Single Test  Average Test

**Save Setting**

Manual Save  Auto Save

**Naming Rules**

Target  +  Number +  Date

Sample  +  Number +  Date

**Heating Die Setting**

Enable Heating Fixture

TargetTem...

CurrentTe... 0.00°C

F-5

# [Data View]

## G

1. On the left of this page, it is the test data of target. On the right, it is the sample data under this target.
2. The bottom left of the page can search and sort the standards or samples according to the name, time or remarks.
3. After choose one of the target, we can see the sample test result under this target on the right.
4. Long press the standard or sample, we can set it into target, modify, delete the current selection, delete all, save to my color library and export report.
5. Click one of the target, user can see the sample information under this target. User can search sample, save and upload the data.
6. Click parameter edit, we can choose the parameter need show on data view interface.

Target search bar

Target List

The screenshot shows a software interface with a dark header bar. The header contains a home icon, the text "Data View", and several parameters: "D65/10° SCI / Reflectance UV400 Cut  $\Phi$  18 22.8°C 34.5%RH". Below the header is a table with a "Target" column on the left and a data area on the right. The "Target" column contains a list of target names from "Target0022" at the top to "Target0013" at the bottom. The data area has a table with columns: "Edit", "Name", "Mode", "L\*", "a\*", "b\*", and "dE". The "Edit" column contains an "Edit" button. Below the table is a control bar with radio buttons for "Target" (selected) and "Sample", a search input field, a "Name" dropdown menu, a "Sort by name" button with an upward arrow, and "Export" and "Import" buttons.

Target	Edit	Name	Mode	L*	a*	b*	dE
Target0022							
Target0021							
Target0020							
Target0019							
Target0018							
Target0017							
Target0016							
Target0015							
Target0014							
Target0013							

G-1

🏠 Data View    D65/10°   SCI   /   Reflectance   UV400 Cut   ϕ 18   22.8°C   34.5%RH

Target	Edit	Name	Mode	L*	a*	b*	dE
Target0022	Target	Target0022	SCI	46.38	-5.91	-23.13	-
Target0021	0	Sample0001	SCI	56.43	-8.13	-36.06	16
Target0020							
Target0019							
Target0018							
Target0017							
Target0016							
Target0015							
Target0014							
Target0013							

Target    Sample   Search   Name ▼   Sort by name ▲

Export   Import

Sample List

Save and upload the current data

G-2

Home | Data View | D65/10° | SCI | Transmittance | UV Include |  $\Phi$  6 | 34.2°C | 56.7%RH

Target Search	Edit	Name	Mode	L*	a*	b*	dE*
Target0074	Target	Target0073	SCI	94.29	-0.24	0.81	--
Target0073	6	Sample0006	SCI	94.29	-0.24	0.81	0.00
Target0072						62.52	62.2
Target0071						39.12	72.4
Target0068						2.64	20.3
Target0067						-23.02	40.0
Target0066						62.52	62.2
Target0065							
Target0064	1	Sample0001	SCI	85.94	-0.46	62.52	62.2
Target0063							
Target0062							
Target0061							

- Set Into Target
- Revise
- Delete Selected
- Delete All

Test Search | Name ▾ | Search | Export | Upload

G-3

Data View    D65/10°    SCI    /    Reflectance    UV400 Cut    Φ 30    22.8°C    23.9%RH

Parameter selection ×

Color space	L*	<input type="checkbox"/> L* <input type="checkbox"/> a* <input type="checkbox"/> b* <input type="checkbox"/> c* <input type="checkbox"/> h	<input type="button" value="ADD"/> <input type="button" value="DELETE"/> <input type="button" value="REMOVE ALL"/>	<div style="border: 1px solid gray; padding: 5px; width: fit-content;"> <p>Selected parameters</p> <p>L*</p> <p>a*</p> <p>b*</p> <p>c*</p> <p>h</p> <p>dE*ab</p> </div>	<input type="button" value="TOP"/> <input type="button" value="UP"/> <input type="button" value="DOWN"/> <input type="button" value="BOTTOM"/>
Color space diff	a*				
Color difference	b*				
Whiteness	c*				
Yellowness	h				
Blackness	X	<input type="button" value="FINISH"/>			
Transmittance	Y				
Color fastness	Z				
Strength	x				
Color density					

# [My Color]



From my color, user can see all the saved data. The data can be set into target or used for finding similar color.

Top of the page: User can select and modify my color library, user can drop down to select different libraries, or click

“Manage” to rename, delete, etc. the color library, or click “Add New” to add a color library;

Middle of the page: the data display under the currently selected color library ( $L^*$ ,  $a^*$ ,  $b^*$  data is Calculated based on  $D65/10^\circ$  );

At the bottom of the page: User can perform data search, display, back-up (requires the insertion of a U disk), add a new data to the current color library, synchronize data to the cloud, delete data, etc.

Home My Color D65/10° SCI / Reflectance UV400 Cut Φ 30 22.9°C 23.7%RH

Select : My Color Library Man... Create Import Lib data from D65/10°

<b>Target0004</b> SCI L* = 75.67 a* = 22.92 b* = -0.46	<b>Sample0001</b> SCI L* = 75.73 a* = 22.78 b* = -0.64	<b>试样0001</b> SCI L* = 71.15 a* = 21.90 b* = -0.24	<b>标样0001</b> SCI L* = 58.79 a* = -11.50 b* = 5.43	<b>标样0002</b> SCI L* = 26.86 a* = 26.61 b* = -20.68
<b>标样0003</b> SCI L* = 72.44 a* = 22.23 b* = -0.39				

Search Backups Create Upload Delete

H-1

My Color D65/10° SCI / Reflectance UV400 Cut ϕ 30 22.9°C 23.7%RH

Select : My Color Li

data from D65/10°

Target0004  
SCI  
L\* = 75.67  
a\* = 22.92

标样0002  
SCI  
L\* = 26.86  
a\* = 26.61

### Color Library Creation

Name My Color Library

Remark

my

q w e r t y u i o p

a s d f g h j k l

z x c v b n m ! ?

?123 , English .

H-2

My Color D65/10° SCI / Reflectance UV400 Cut  $\Phi$  30 22.9°C 23.7%RH

Select : My Color Library    data from D65/10°

Target0004  
SCI  
L\* = 75.67  
a\* = 22.92  
b\* = -0.46

标样0003  
SCI  
L\* = 72.44  
a\* = 22.23  
b\* = -0.39

标样0002  
SCI  
L\* = 26.86  
a\* = 26.61  
b\* = -20.68

Color Library Creation

Name

Remark

H-3

My Color D65/10° SCI / Reflectance UV400 Cut  $\Phi$  30 22.9°C 23.7%RH

Select : My Color Libra data from D65/10°

Target0004  
SCI

L\* = 75.67  
a\* = 22.92  
b\* = -0.46

---

标样0003  
SCI

L\* = 72.44  
a\* = 22.23  
b\* = -0.39

Enter Keyword

**Color Detail** ✕

L\* = 75.67  
a\* = 22.92  
b\* = -0.46

Spectrum Curve

Wavelength (nm)

Name

Remark

Set Into Target
Finish

Create Time : 2016-01-01 13:11:57

标样0002  
SCI

L\* = 26.86  
a\* = 26.61  
b\* = -20.68

Upload Delete

🏠 My Color    D65/10°   SCI   /   Reflectance   UV400 Cut   Φ 30   22.8°C   24.6%RH

Select :             data from D65/10°

---

<p>Target0004 SCI</p> <p>L* = 75.67 a* = 22.92 b* = -0.46</p>	<p>Sample0001 SCI</p> <p>L* = 75.73 a* = 22.78 b* = -0.64</p>	<p>试样0001 SCI</p> <p>L* = 71.15 a* = 21.90 b* = -0.24</p>	<p>标样0001 SCI</p> <p>L* = 58.79 a* = -11.50 b* = 5.43</p>	<p>标样0002 SCI</p> <p>L* = 26.86 a* = 26.61 b* = -20.68</p>
<p>标样0003 SCI</p> <p>L* = 72.44 a* = 22.23 b* = -0.39</p>				

H-5

My Color D65/10° SCI / Reflectance UV400 Cut Φ 30 22.8°C 24.6%RH

Select :

### Create My Color

Manual Input Instrument Measure

SCI  SCE

L\*:  L\*:

a\*:  a\*:

b\*:  b\*:

Name

Remark

Preview

FINISH

Target L\* = a\* = b\* =

02 .86 .61 0.68

Enter K Delete

H-6

My Color D65/10° SCI / Reflectance UV400 Cut Φ 30 22.8°C 24.6%RH

Select :

Target

L\* =  
a\* =  
b\* =

標

L\* =  
a\* =  
b\* =

Enter K

Delete

### Create My Color

Manual Input Instrument Measure

SCI

L\*:  
a\*:  
b\*:  
360nm:  
370nm:  
380nm:  
390nm:

Measure

FINISH

H-7

# [Individual Center]



User can revise the account password and cancel the current account.

Individual Center D65/10° SCI / Reflectance UV400 Cut  $\phi$  30 23.0°C 24.1%RH

Account: admin

Company Name

Address

Contact Name

Email

Change Password

Old Password

New Password

New Password Confirm

Enter

Logout



# [About]

J-1

User can check instrument information such as software version, instrument version, serial number, model, etc.

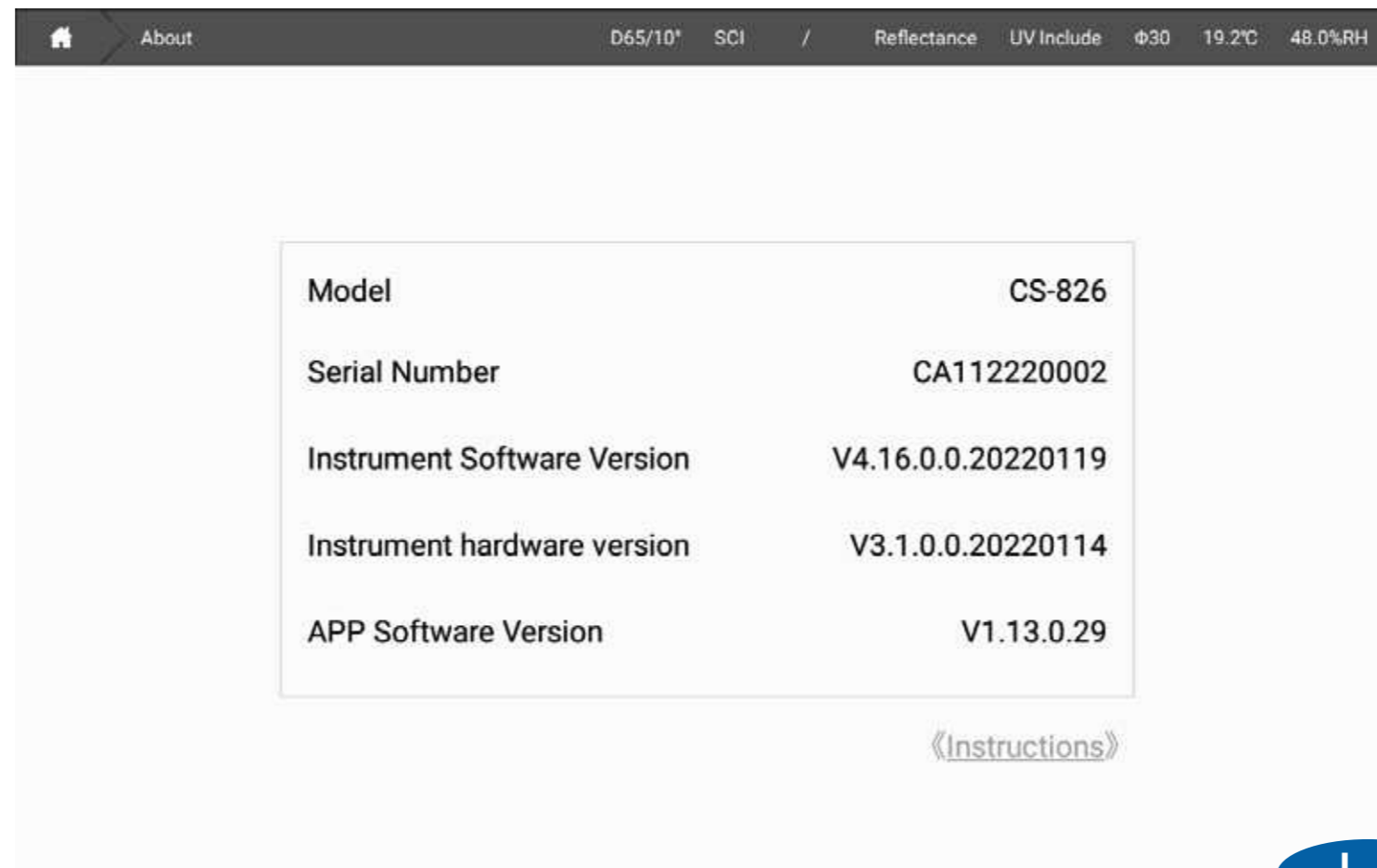

J-1

# [Daily Record]

K-1

User can see the instrument information of login, calibration, error, etc.

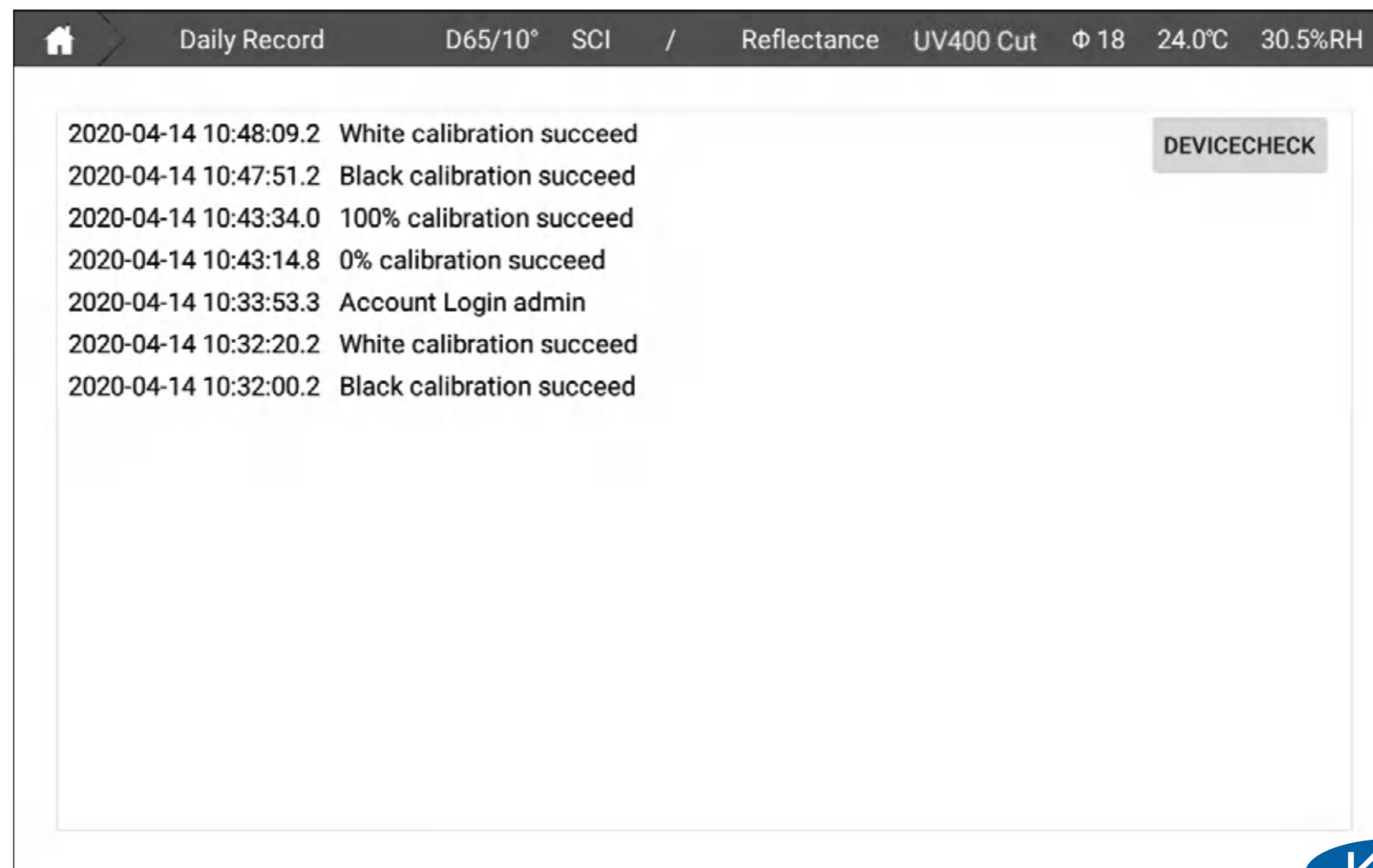

K-1

# [Update]

L-1

Connect with internet, click update to update the instrument software into the latest.

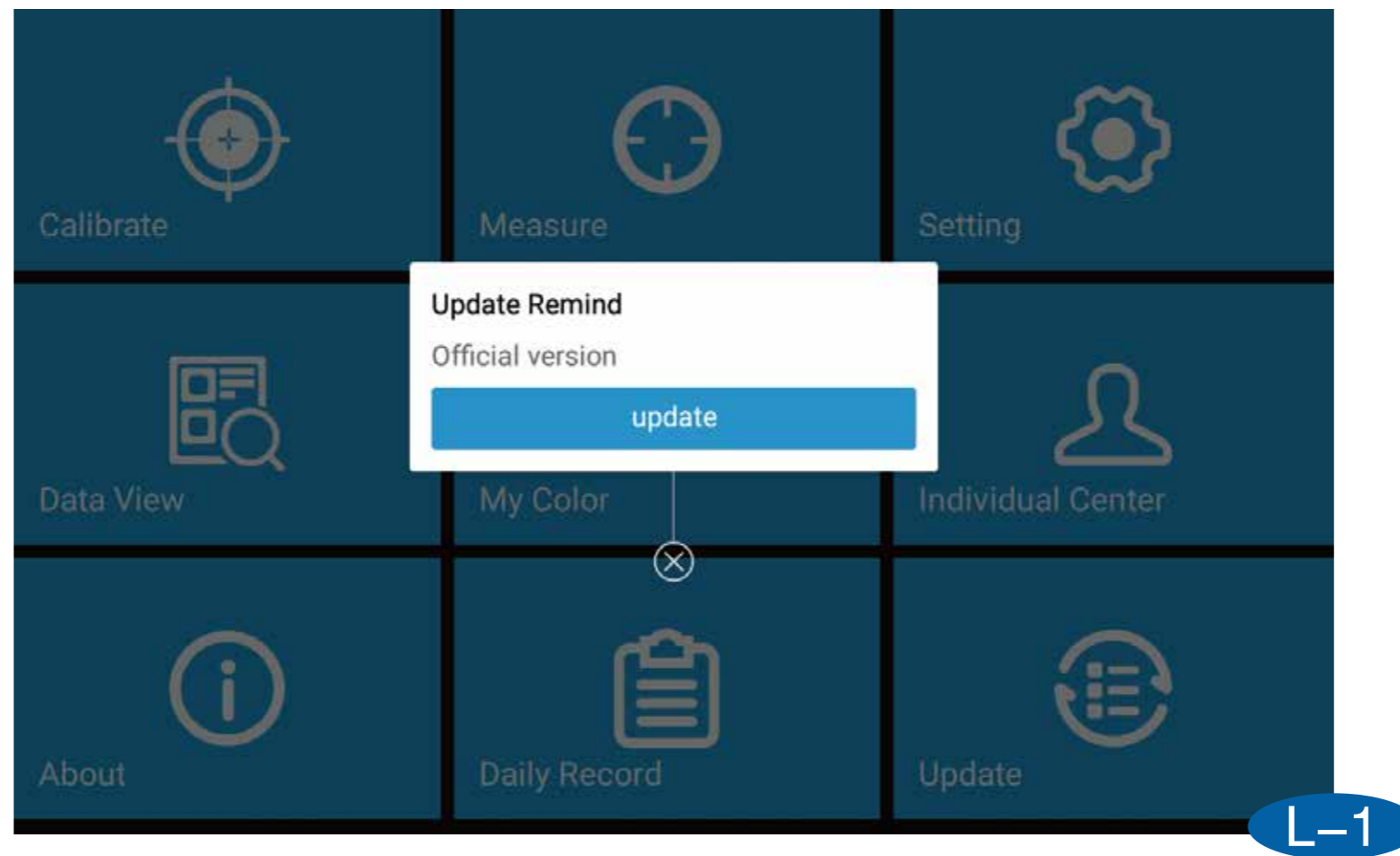

# Measure Interface Introduction

## [Color Difference]

M-1

### **CIELABCH**

Under this interface, user can get sample  $L^*$ ,  $a^*$ ,  $b^*$ ,  $c^*$ ,  $h$  values, color difference value  $dL^*$ ,  $da^*$ ,  $db^*$ ,  $dc^*$ ,  $dH^*$ , and  $dE^*_{ab}$  comparing with the target and check if the sample is qualified or not according to the tolerance.



Measure

D65/10° SCI /

Reflectance

UV400 Cut

Φ 18

24.0°C

30.5%RH

Test Target

Test Sample

### Target

L\* = 64.31  
a\* = 11.26  
b\* = 15.70  
c\* = 19.32  
h = 54.34

### Sample

L\* = 65.78  
a\* = 10.51  
b\* = 15.73  
c\* = 18.91  
h = 56.26

dL\* = 1.47 **Pass**  
da\* = -0.76 **Pass**  
db\* = 0.03 **Pass**  
dc\* = -0.41 **Pass**  
dH\* = 0.64 **Pass**

dE\*ab  
**1.65 Pass**



Camera



Setting



Report



Save



Measure

M-1

# M-2

## CIEDE2000

Under this interface, user can get sample  $L^*$ ,  $a^*$ ,  $b^*$ ,  $c^*$ ,  $h$  values, color difference value  $dL'$ ,  $dC'$ ,  $dH'$  and  $dE^*2000$  comparing with the target and check if the sample is qualified or not according to the tolerance.

The screenshot shows a software interface for color measurement. At the top, it displays 'Measure' and various settings: 'D65/10° SCI Reflectance UV Include Φ 6 34.2°C 56.7%RH'. Below this, there are two tabs: 'Test Target --- Target0023' and 'Test Sample --- Sample0012'. The interface is divided into three main sections: 'Target', 'Sample', and 'Color Difference'. The 'Target' and 'Sample' sections show the following values:

Parameter	Target	Sample
$L^*$	55.07	55.07
$a^*$	47.12	47.12
$b^*$	39.12	39.12
$c^*$	61.24	61.24
$h$	39.70	39.70

The 'Color Difference' section shows the following values:

$dL'$	0.00	Pass
$dC'$	0.00	Pass
$dH'$	0.00	Pass
$dE^*2000$	0.00	Pass

On the right side of the interface, there are four icons: 'Camera', 'Setting', 'Save', and 'Measure'.

M-2

# M-3

## CIE94

Under this interface, user can get sample  $L^*$ ,  $a^*$ ,  $b^*$ ,  $c^*$ ,  $h$  values, color difference value  $dL^*$ ,  $da^*$ ,  $dc^*$ ,  $dH^*$  and  $dE^*94$  comparing with the target and check if the sample is qualified or not according to the tolerance.

The screenshot shows a mobile application interface for color measurement. At the top, it displays 'Measure' and various settings: 'D65/10° SCI / Reflectance UV400 Cut Φ 18 24.0°C 30.5%RH'. Below this, there are two tabs: 'Test Target -- Target0013' and 'Test Sample -- Sample0001'. The interface is divided into three main sections: 'Target', 'Sample', and 'Difference'. The 'Target' section lists:  $L^* = 67.31$ ,  $a^* = 10.31$ ,  $b^* = 15.84$ ,  $c^* = 18.91$ , and  $h = 56.95$ . The 'Sample' section lists:  $L^* = 67.75$ ,  $a^* = 10.21$ ,  $b^* = 15.99$ ,  $c^* = 18.97$ , and  $h = 57.44$ . The 'Difference' section shows:  $dL^* = 0.43$  Pass,  $da^* = -0.10$  Pass,  $db^* = 0.14$  Pass,  $dc^* = 0.07$  Pass,  $dH^* = 0.16$  Pass, and  $dE^*94 = 0.45$  Pass. On the right side, there is a vertical menu with icons for Camera, Setting, Report, Save, and Measure.

Target	Sample	Difference
$L^* = 67.31$	$L^* = 67.75$	$dL^* = 0.43$ Pass
$a^* = 10.31$	$a^* = 10.21$	$da^* = -0.10$ Pass
$b^* = 15.84$	$b^* = 15.99$	$db^* = 0.14$ Pass
$c^* = 18.91$	$c^* = 18.97$	$dc^* = 0.07$ Pass
$h = 56.95$	$h = 57.44$	$dH^* = 0.16$ Pass
		$dE^*94 = 0.45$ Pass

M-3

M-4

## CMC

Under this interface, user can get sample  $L^*$ ,  $a^*$ ,  $b^*$ ,  $c^*$ ,  $h$  values, color difference value  $dL^*$ ,  $da^*$ ,  $dc^*$ ,  $dH^*$  and  $dE_{cmc}(1:c)$  comparing with the target and check if the sample is qualified or not according to the tolerance.

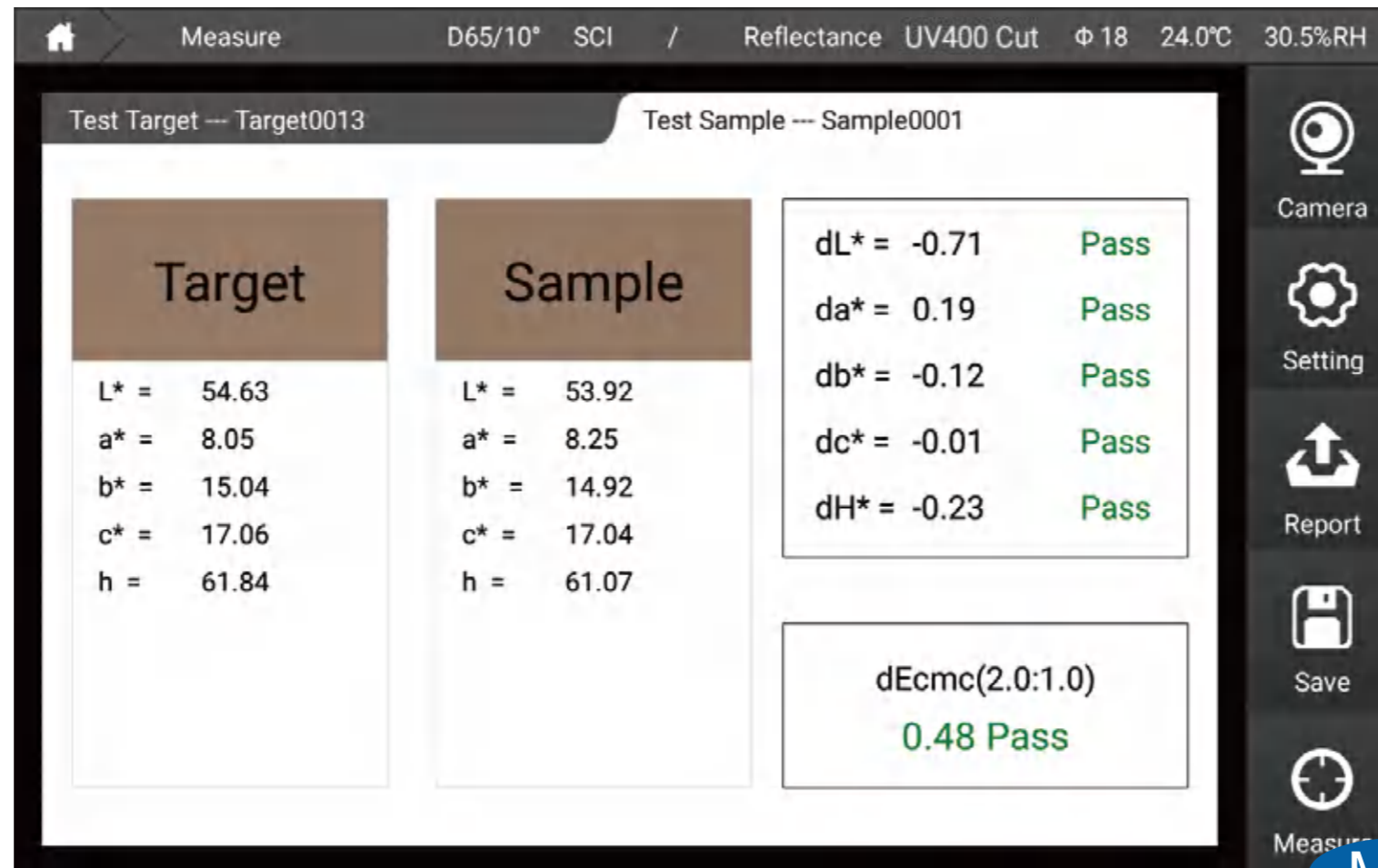

M-4

# M-5

## Hunter Lab

Under this interface, user can get sample Hunter L, Hunter a, Hunter b values, color difference value dHunter L, dHunter a, dHunter b and dE ab comparing with the target and check if the sample is qualified or not according to the tolerance.

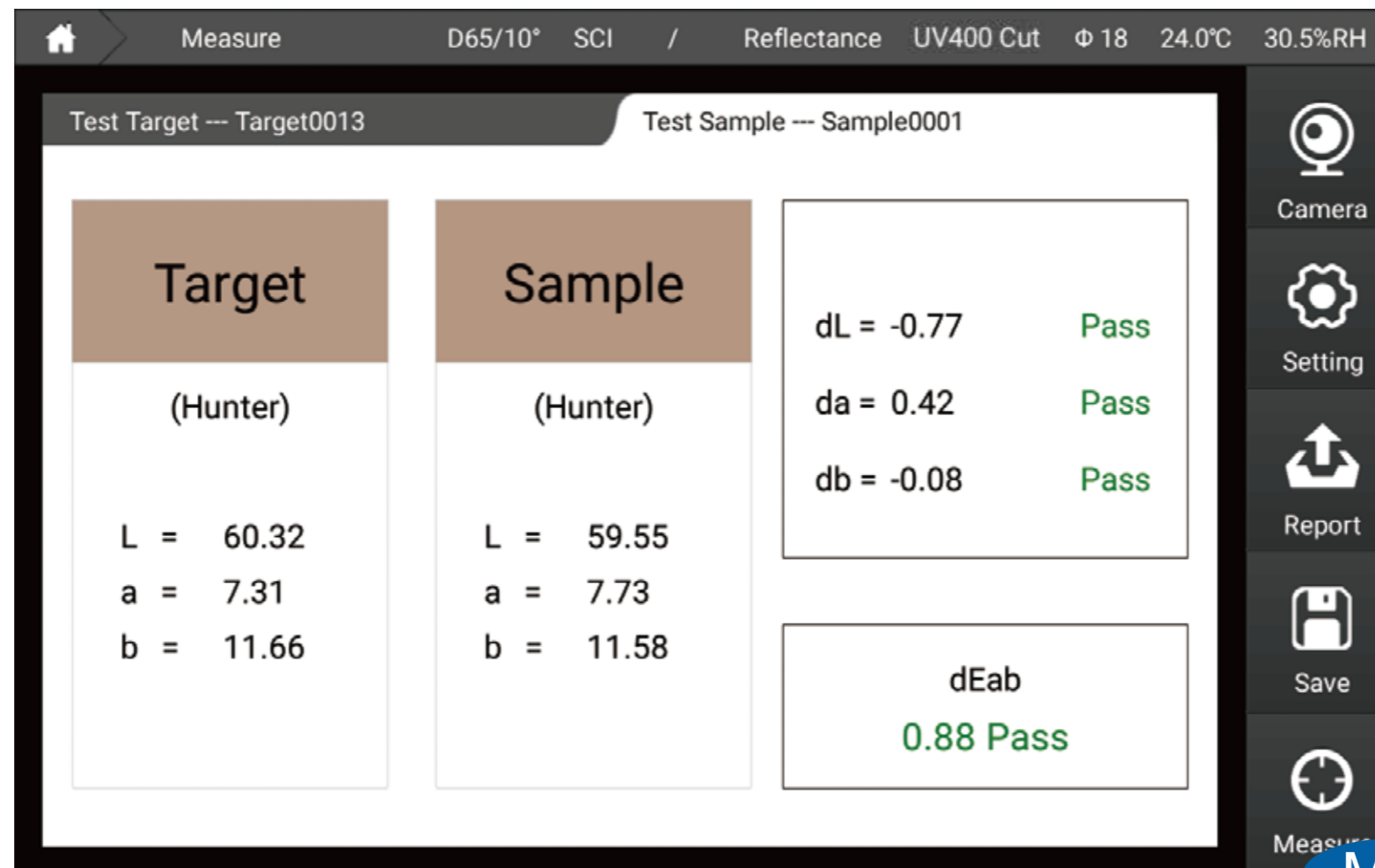

# M-6

# [Data]

## N-1

1. Click parameter edit, we can edit the parameter.
2. Measure the target, then measure the sample to check the color difference.  
Click the data, we can choose it to edit its name, delete, etc.
3. Click the data, we can choose it to edit its name, delete, etc.

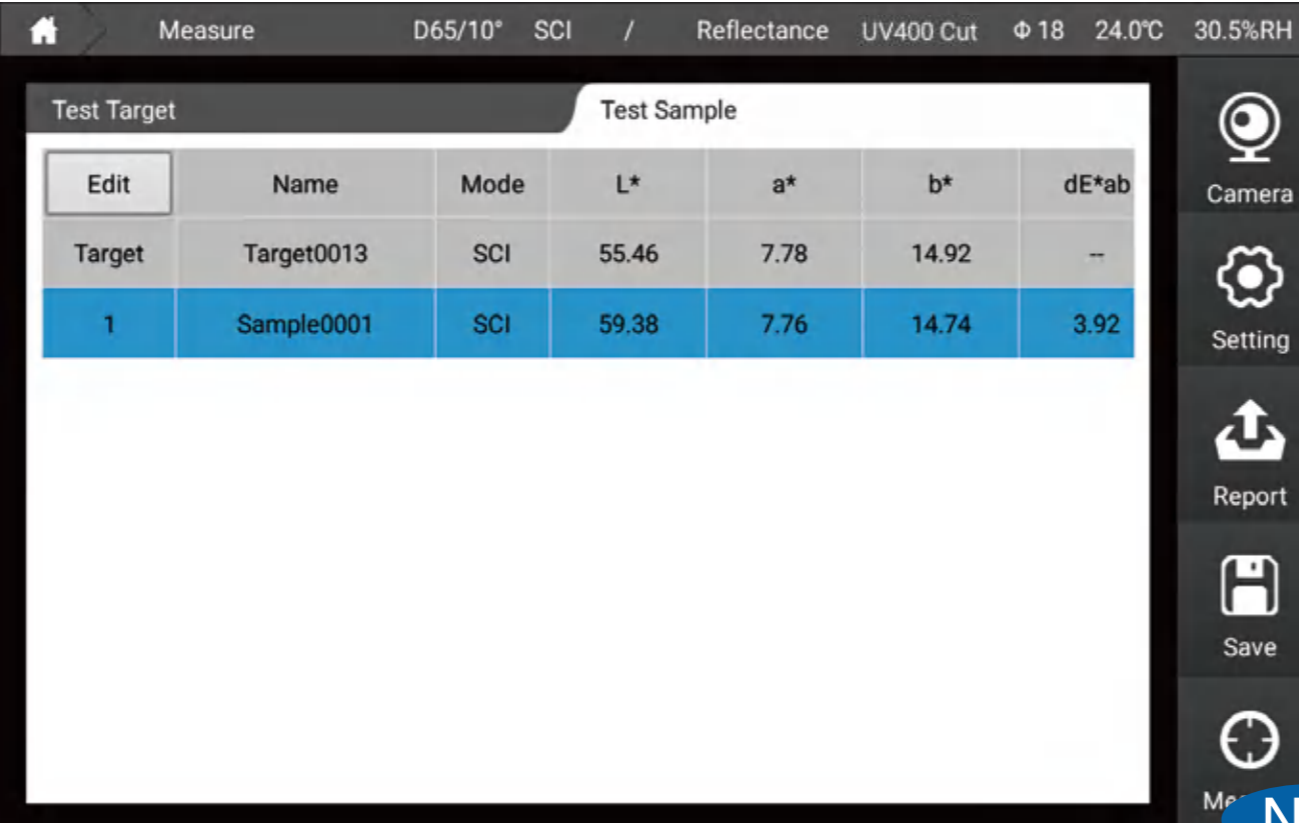

The screenshot shows a mobile application interface for color measurement. At the top, it displays 'Measure' and various settings: 'D65/10° SCI / Reflectance UV400 Cut Φ 18 24.0°C 30.5%RH'. Below this, there are two tabs: 'Test Target' and 'Test Sample'. The 'Test Sample' tab is active, showing a table with the following data:

Edit	Name	Mode	L*	a*	b*	dE*ab
Target	Target0013	SCI	55.46	7.78	14.92	--
1	Sample0001	SCI	59.38	7.76	14.74	3.92

On the right side of the screen, there is a vertical menu with icons for 'Camera', 'Setting', 'Report', 'Save', and 'Me'.

N-1

[Figure]

0-1

## CIELAB

Under this interface, user can measure sample  $L^*$ ,  $a^*$ ,  $b^*$  values, sample position in the color space and color lab value will show.

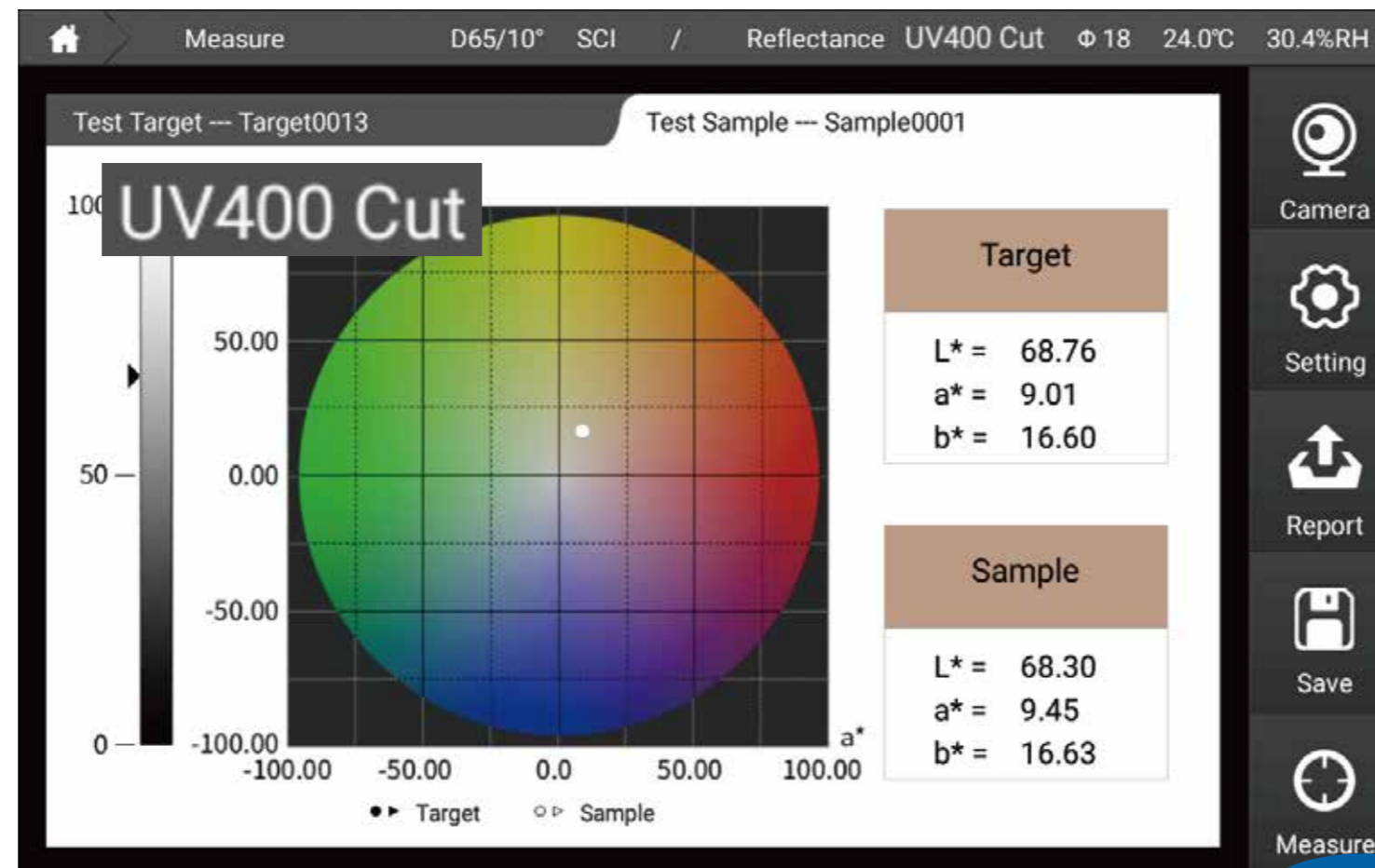

0-1

0-2

## Yxy

Under this interface, user can measure sample Y,x,y values, sample x,y value in the color space and Yxy value will show.

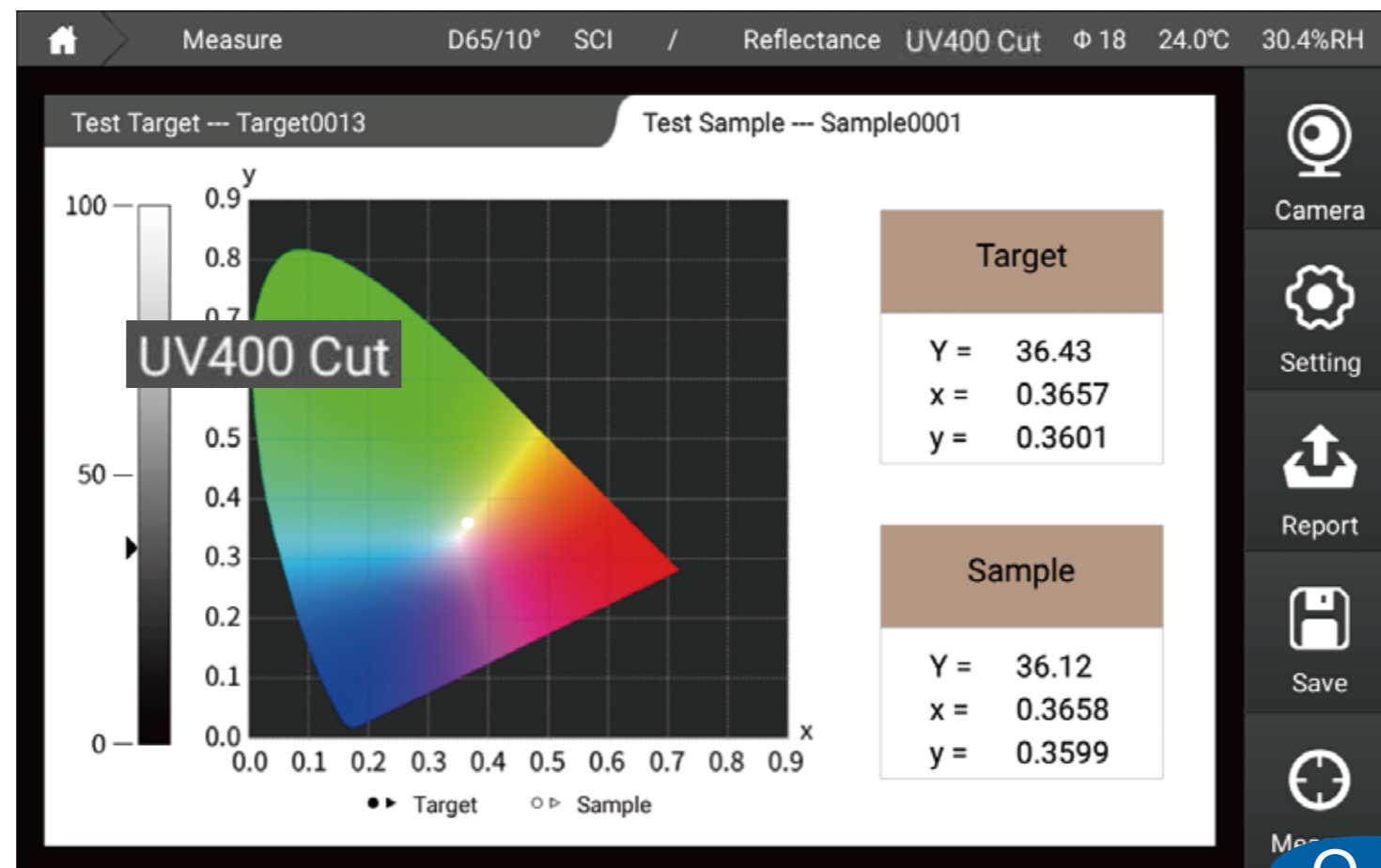

0-2

# 0-3

## Luv

Under this interface, user can measure sample  $L^*, u^*, v^*$  values, sample  $u', v'$  value in the color space and  $L^*, u^*, v^*$  value will show.

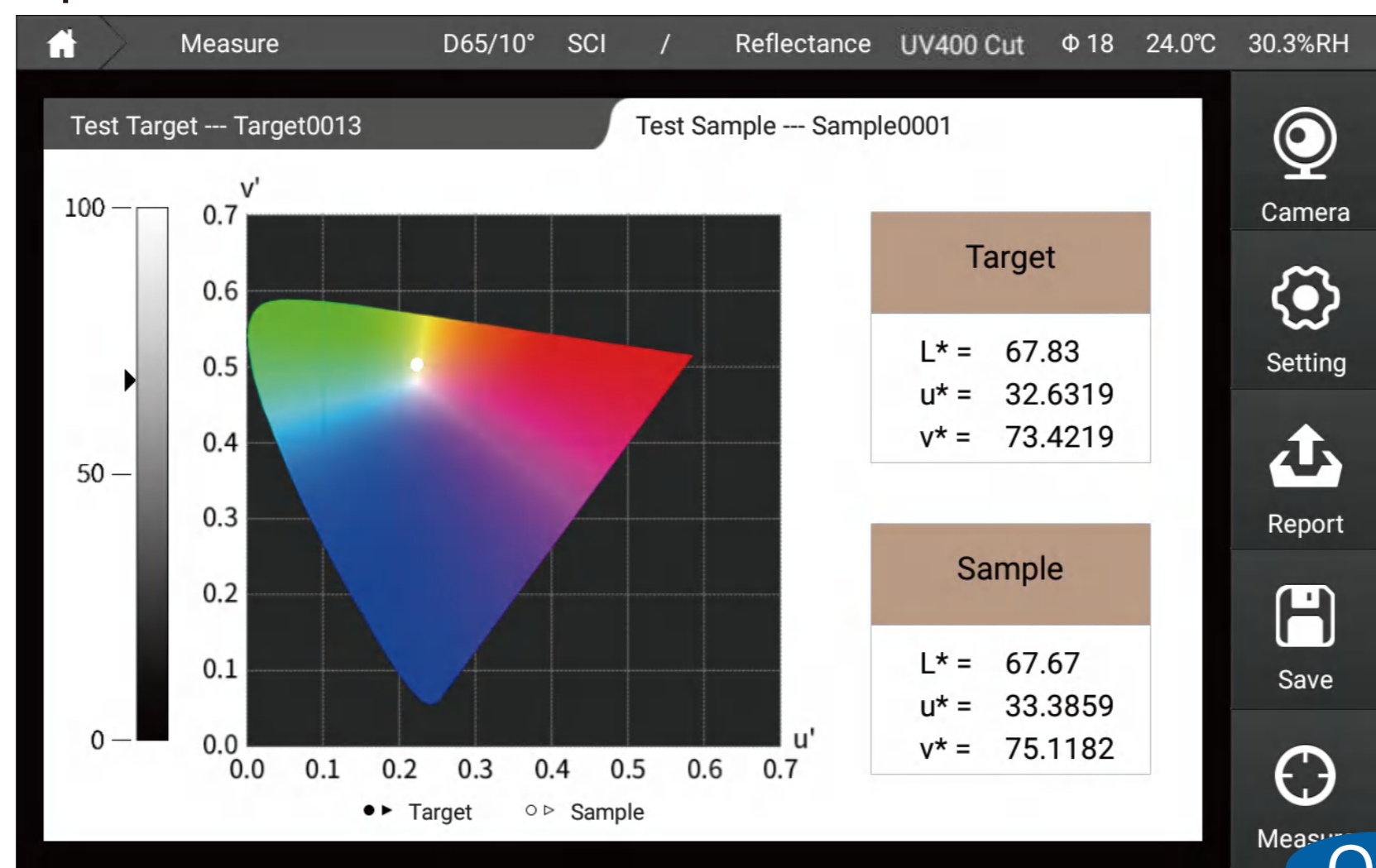

# 0-3

0-4

### K/S Curve

User can measure and get sample K/S value and K/S curve under 360-780nm wavelength.

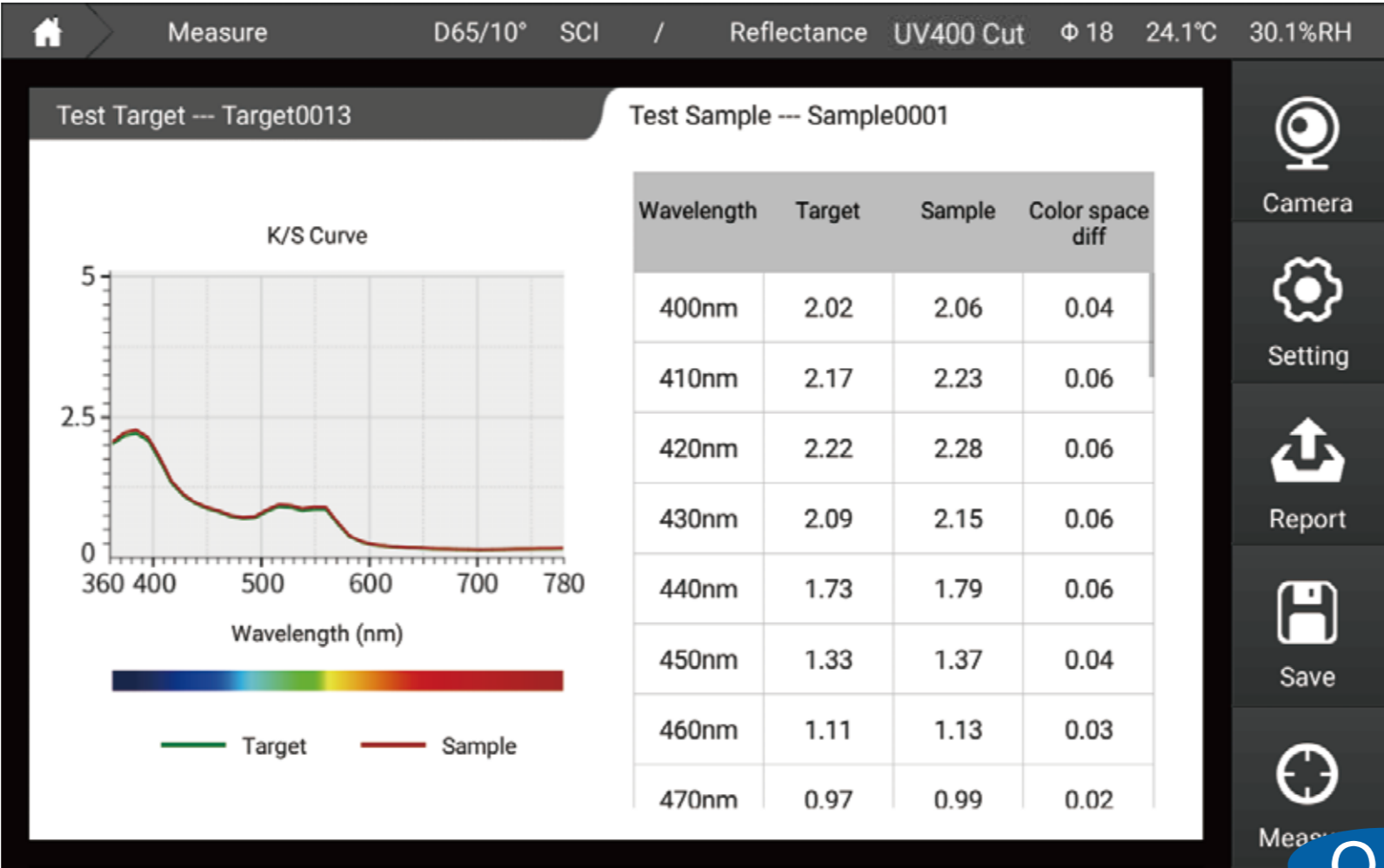

0-4

0-5

## Reflectance Curve

User can measure and get sample reflectance value and curve under 360-780nm wavelength.

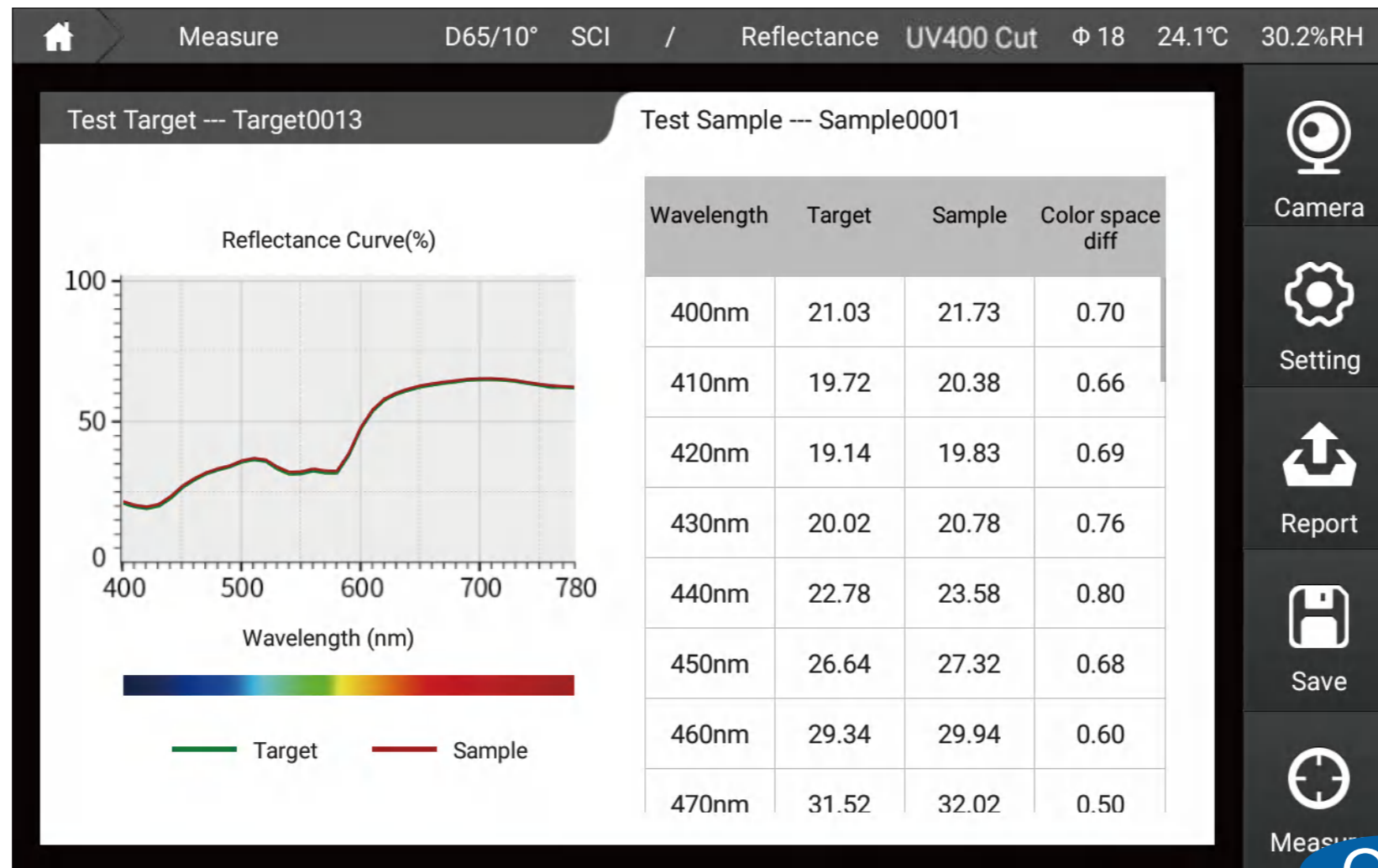

0-5

0-6

## Transmittance Curve

User can measure and get sample transmittance value and curve under 360-780nm wavelength.

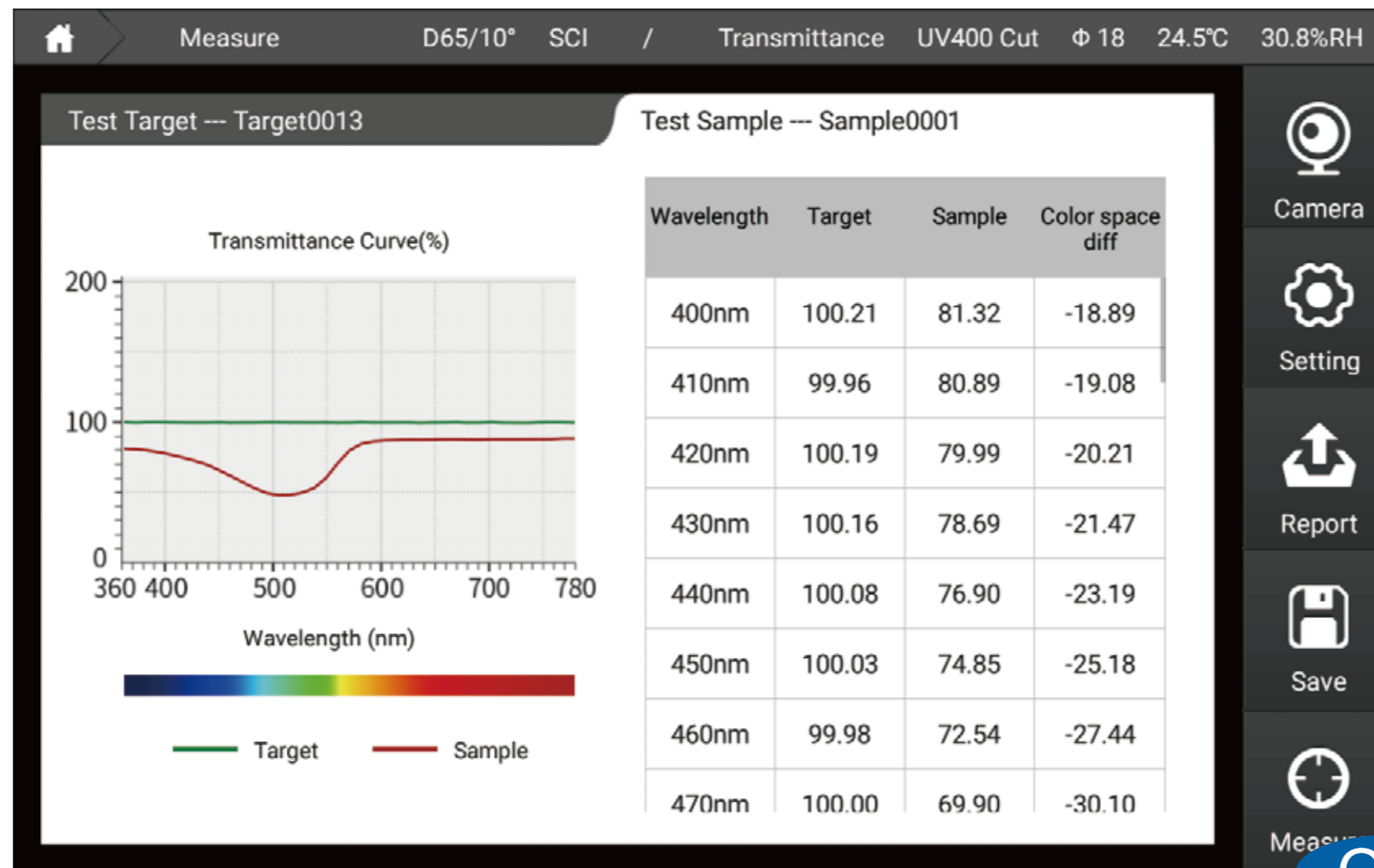

0-6

0-7

# Absorbance Curve

User can measure and get sample absorbance value and curve under 360-780nm wavelength.

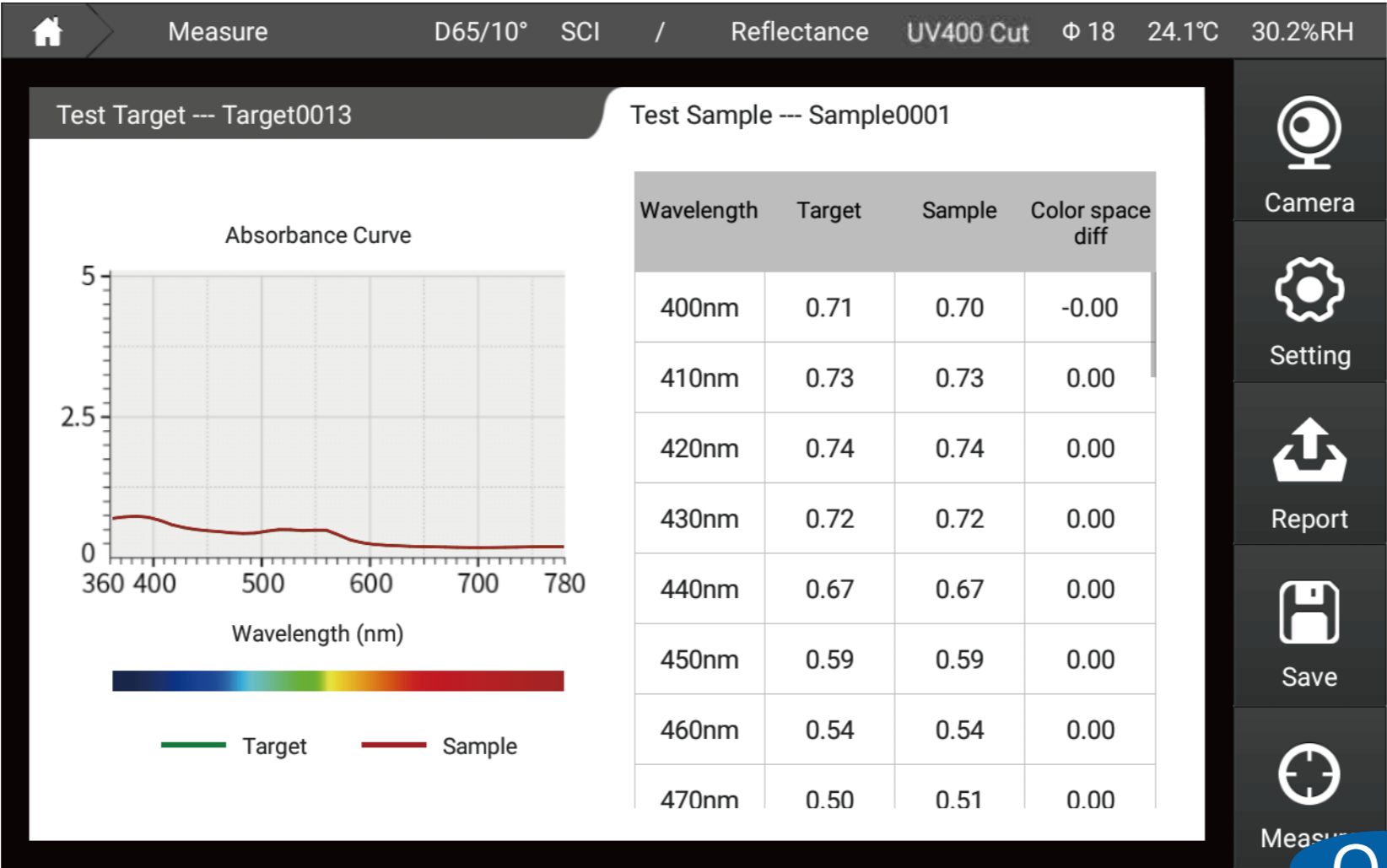

0-7

# [Haze]

## P-1

After choose haze parameter, the instrument can automatically switch into transmittance mode, C light source and 2 ° viewing angle.

Two steps for measuring haze:

1. Fix white tile into reflectance aperture, put sample on transmittance aperture.
2. Fix black cavity into reflectance aperture, put sample on transmittance aperture.

When enter into haze measure page, instrument will remind calibration, after calibration, we can measure sample. Calibration need only to be done once when the instrument is switched on or enter into haze measure page.

Measure C/2° SCI / Transmittance UV400 Cut  $\phi$  18 24.2°C 30.3%RH

Test Target --- Target0013 Test Sample

Transmittance Curve(%)

SWITCH H Illuminants/Angles C/2°	
Haze	Total Transmittance
8.71	62.61

Wavelength (nm)

Camera  
Setting  
Report  
Save  
Measure

P-1

# [Opacity]

## Q-1

1. Two steps for measuring opacity :

Measure the sample which is painted on white cardboard then measure the sample which is painted on black cardboard.

2. The left is the sample's  $L^*$ ,  $a^*$ ,  $b^*$  and  $Y$  value on black cardboard and the right is the sample's  $L^*$ ,  $a^*$ ,  $b^*$  and  $Y$  on white cardboard.

3. The sample measurement interface can compare the  $L^*$ ,  $a^*$ ,  $b^*$ , and  $Y$  values of in white and black background respectively, then calculate and display  $dL^*$ ,  $da^*$ ,  $db^*$ ,  $dc^*$ ,  $dE^*$ ,  $dY$  and  $dOpacity$  comparing to the standard.

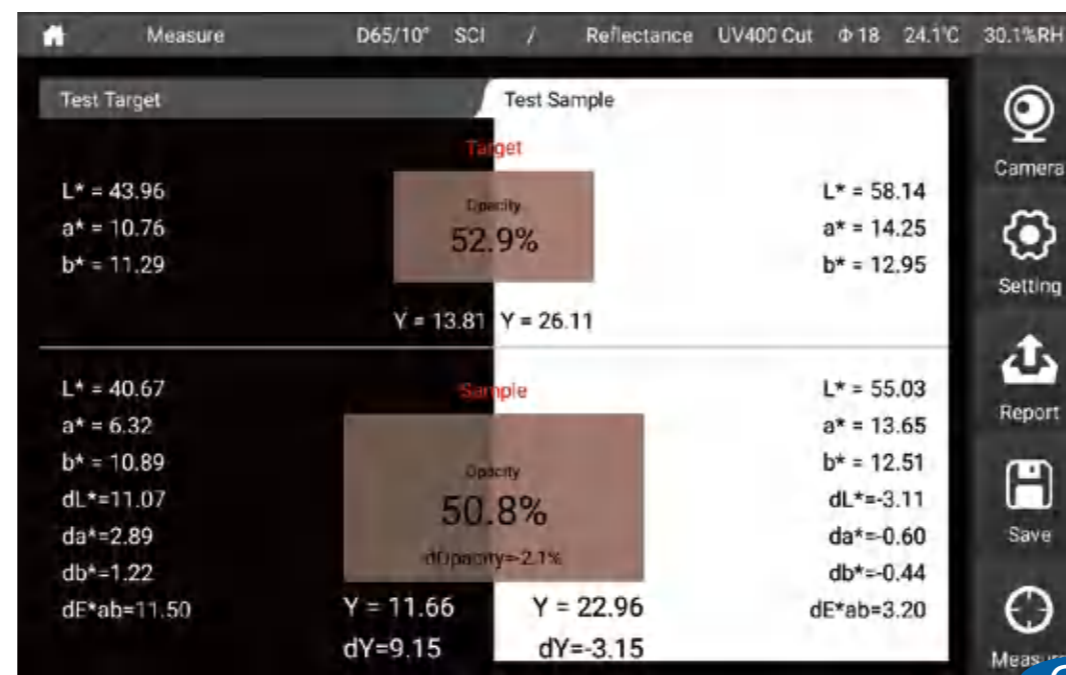

# [Metamerism]

## R-1

The left side is the sample's color value calculated by the first illuminant and angle, and the right side is the sample's color value calculated by the second illuminant and angle. Metamerism is the value calculated by the same sample under two angles of the two illuminants.

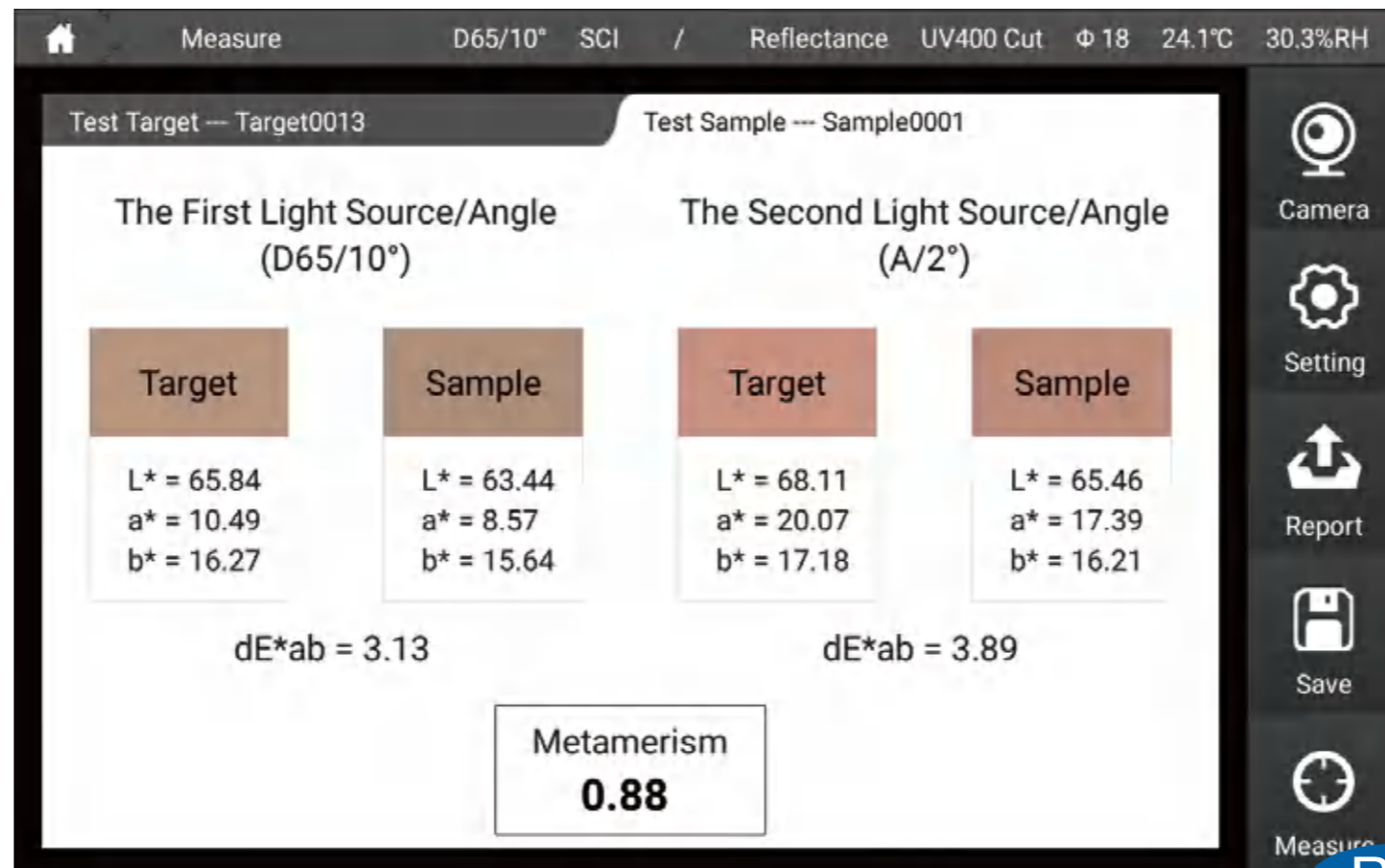

## R-1

# [Liquid Chromaticity]

## S-1

- 1. When choose liquid chromaticity, the instrument can automatically switch into transmittance mode, C light source and 2 ° viewing angle.
- 2. The left side is the glass cell light path and standards. (for example if user want to measure Saybolt, glass cell with 50mm light path will be recommended) The right side is the value and pass/fail result.

The screenshot shows the 'Measure' screen of a color instrument. At the top, it displays 'C/2° SCI / Transmittance UV400 Cut ϕ 18 24.3°C 30.7%RH'. Below this, there are tabs for 'Test Target -- Target0013' and 'Test Sample -- Sample0001'. A 'SWITCH' button is set to 'Illuminants/Angles C/2°'. The main area contains a table with the following data:

Cuvette Light Path	Parameter	Target	Sample	Color space diff	Judge
10mm	Pt-Co/Hazen/APHA	1.42	0.90	-0.52	Pass
10mm	Gardner Color	0.00	0.00	0.00	Pass
50mm	Saybolt	30	30	0	Pass
33mm	ASTM Color	0.3	0.3	0.0	Pass

On the right side of the screen, there is a vertical menu with icons for Camera, Setting, Report, Save, and Measure.

## S-1

# [Find Similar Color]

## T-1

1. Enter into find similar color interface, instrument will remind set the instrument into D65/10/SCI mode, choose yes, instrument mode will be into D65/10/SCI mode.
2. On the left is the sample  $L^*$ ,  $a^*$ ,  $b^*$  value, under the color value, it is the "my color library" and we can also set how many pieces result to search.
3. On the right side is the similar colors. We can choose from different color library and set how many pieces of result to show. When we change the color library or change the number, the new result will show on right side.

Home | Measure | D65/10° SCI / Reflectance UV400 Cut Φ 18 24.1°C 30.4%RH

---

  
 $L^* = 55.77$   
 $a^* = 7.72$   
 $b^* = 14.78$

Color Library : My Color Li... ▾

Search Quantity : 6 ▾

### Search Result

Target0013	Sample0001
$L^* = 64.31$ $a^* = 11.26$ $b^* = 15.70$ $dE^*ab = 9.29$	$L^* = 65.78$ $a^* = 10.51$ $b^* = 15.73$ $dE^*ab = 10.43$
标样0013	试样0001
$L^* = 25.47$ $a^* = -0.11$ $b^* = -0.05$ $dE^*ab = 34.63$	$L^* = 19.32$ $a^* = 1.22$ $b^* = -4.93$ $dE^*ab = 41.95$

Camera

Setting

Report

Save

Measure

T-1

# [Color Master Batches]

## U-1

This interface is dedicated to the measurement of color master batches, please follow the prompts to measure. There are parameter settings in the top right, 10 parameters can be added at most.

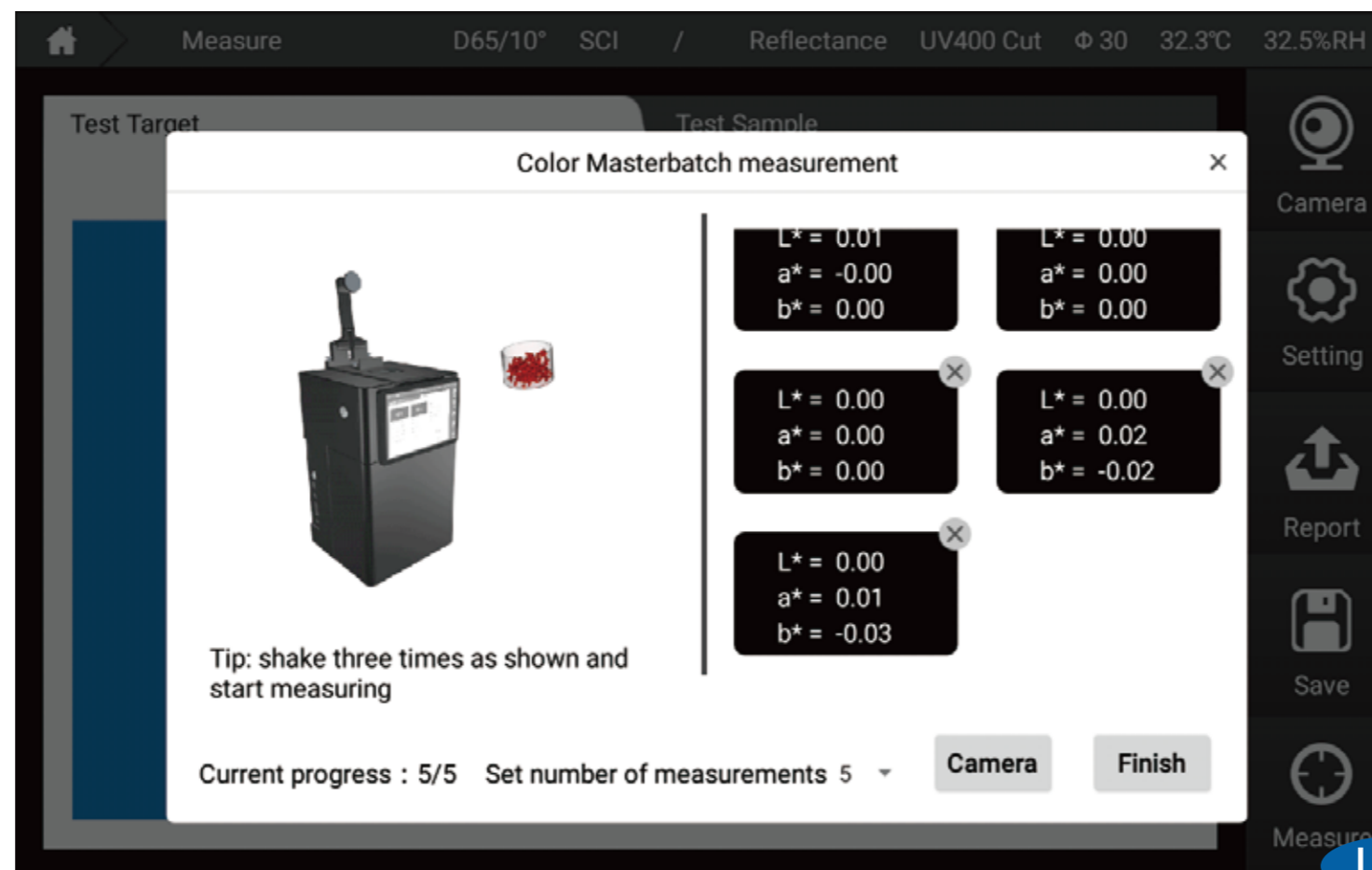

## U-1

# [Titanium Dioxide]

V-1

This interface is dedicated to the measurement of titanium dioxide, please follow the prompts to measure. There are parameter settings in the top right, 10 parameters can be added at most.

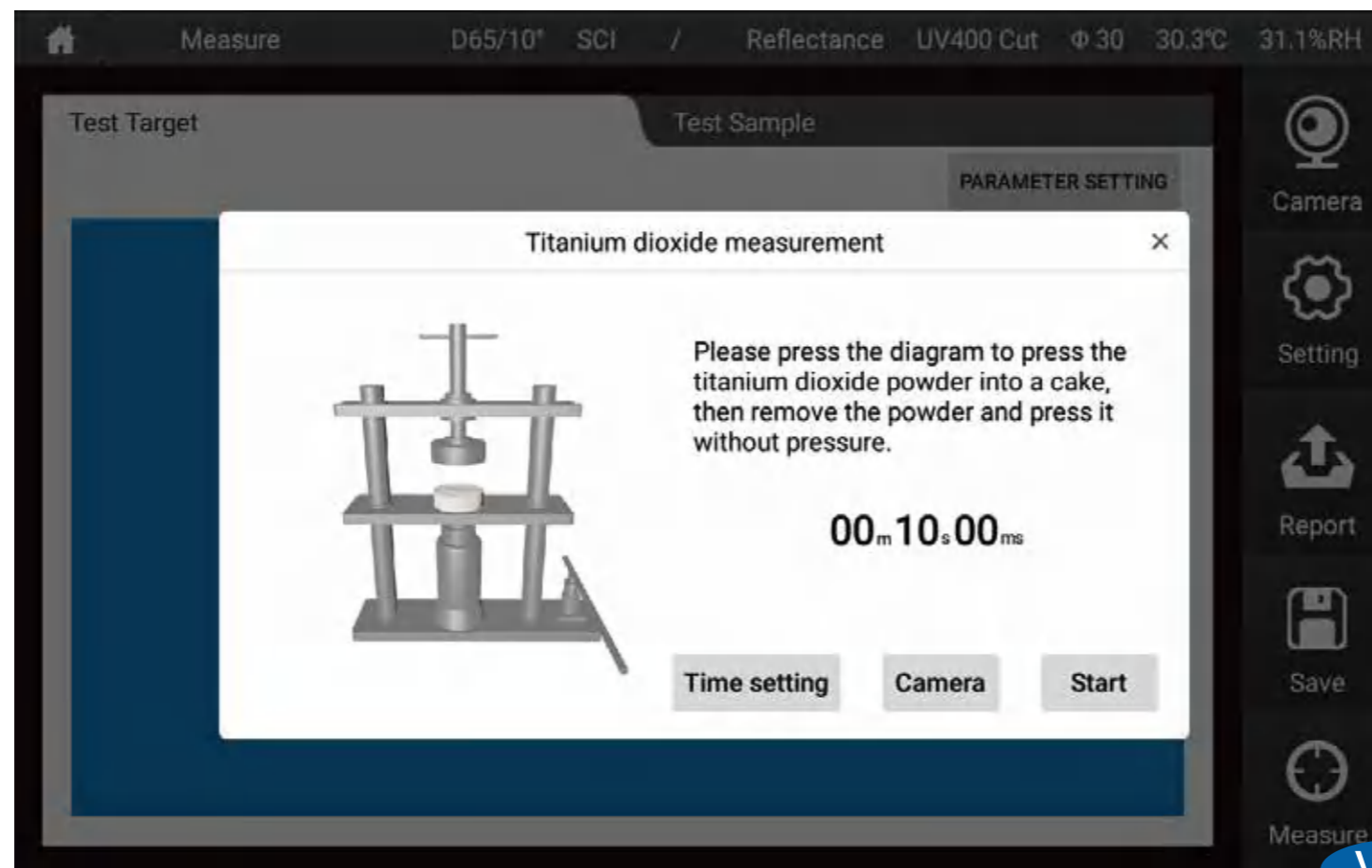

V-1

# [ Paste]

W-1

This interface is dedicated to the measurement of paste, please follow the prompts to measure. There are parameter settings in the top right, 10 parameters can be added at most.

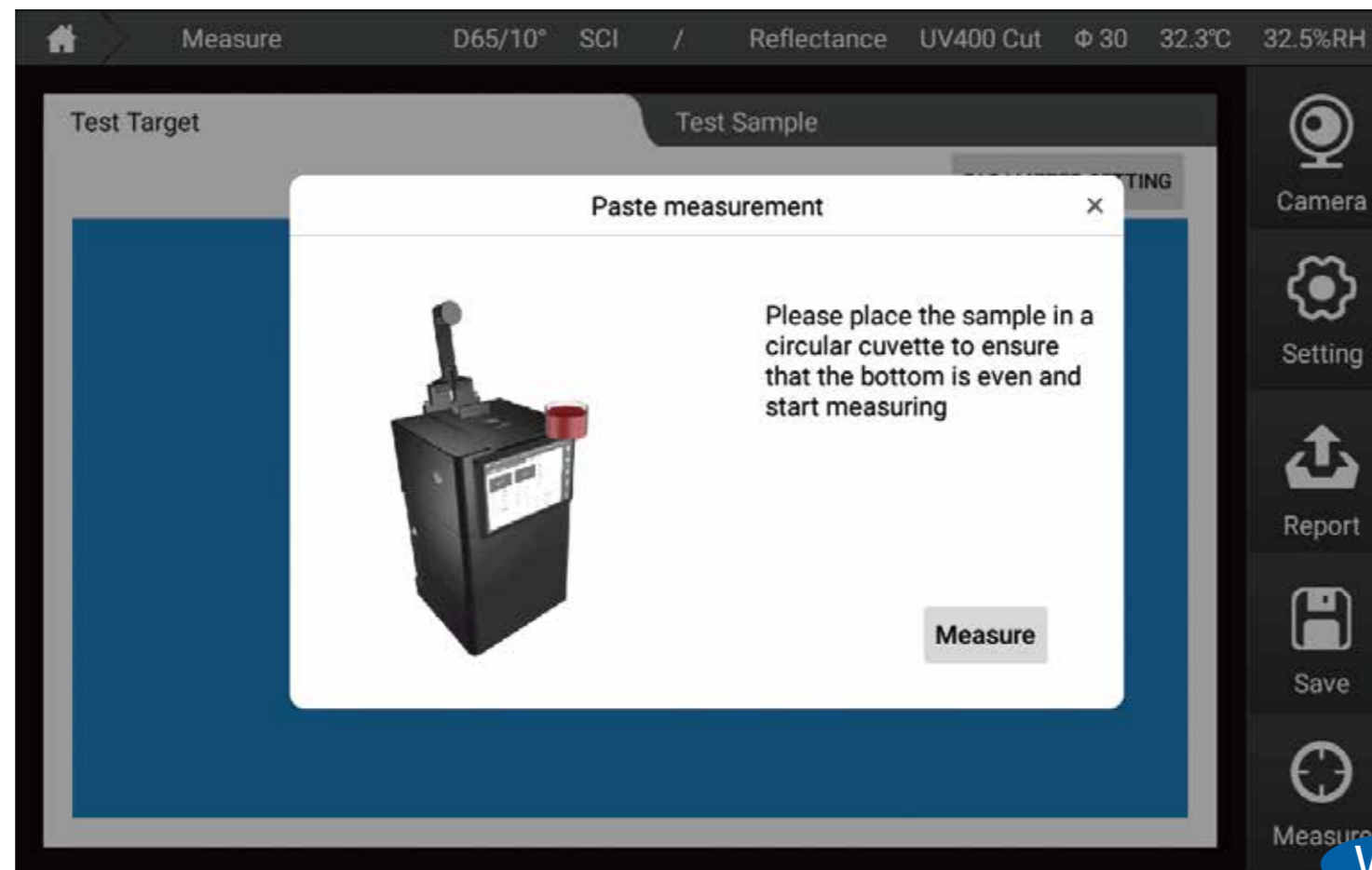

W-1

# Trouble Shooting

Error	Analysis	How to Solve
1. Instrument can not switch on	Check if the instrument is connected with the power successfully	Make sure power cord interface is well connected
2. Calibration Failed	<ol style="list-style-type: none"> <li>1. Check if white tile is on aperture for black calibration.</li> <li>2. Check if black cavity is on aperture for white calibration.</li> <li>3. Transmittance calibration operation is wrong.</li> </ol>	<ol style="list-style-type: none"> <li>1. Make sure black cavity is used for black calibration and white tile is used for white calibration.</li> <li>2. Follow the instrument instruction when do transmittance calibration.</li> </ol>
3. Error in measurement results	Check if the tolerance setting is reasonable	Check and change tolerance setting
4. Unreasonable test results	<ol style="list-style-type: none"> <li>1. Check if there is space between instrument aperture and sample.</li> <li>2. Check if the sample surface is with scratches.</li> <li>3. Check if instrument test mode is right.</li> </ol>	<ol style="list-style-type: none"> <li>1. Make sure no space between measurement aperture and sample.</li> <li>2. Make sure the sample surface is good and flat.</li> <li>3. Set instrument mode before measure.</li> </ol>
5. Wrong Aperture Recognition	<ol style="list-style-type: none"> <li>1. Measuring aperture is not placed on instrument.</li> <li>2. Aperture is placed in wrong direction.</li> </ol>	<ol style="list-style-type: none"> <li>1. Check if the reflectance test aperture is placed on instrument or not.</li> <li>2. Check if the direction of the reflectance test aperture is right or not. Try to turn it over.</li> </ol>

# Accessories

## Standard Accessories

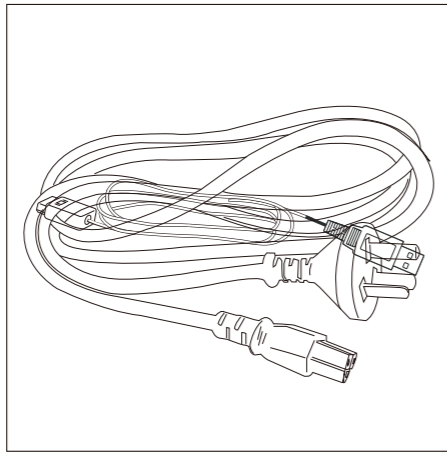

Power Adaptor

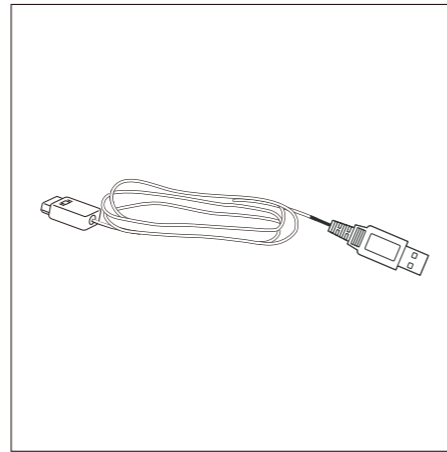

USB Cable

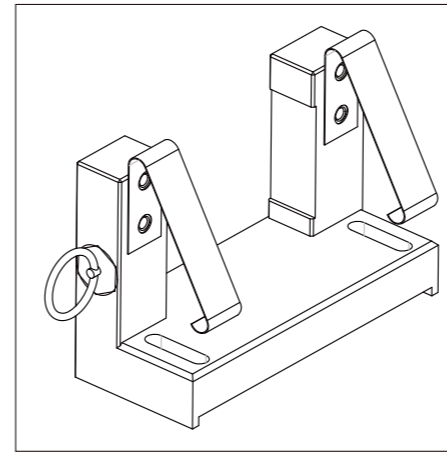

Transmittance Fixture

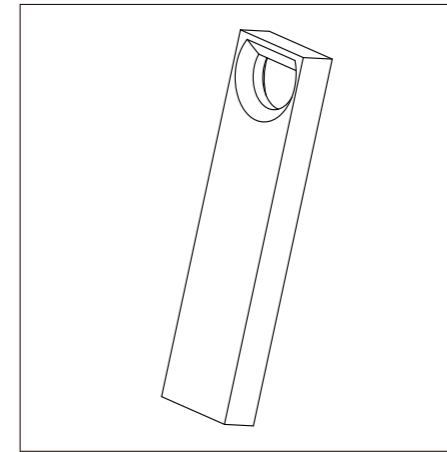

USB Disk

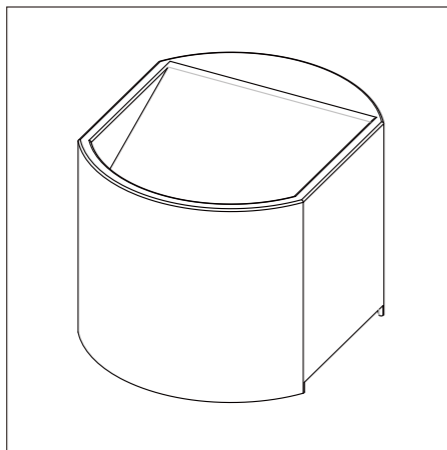

Black Cavity

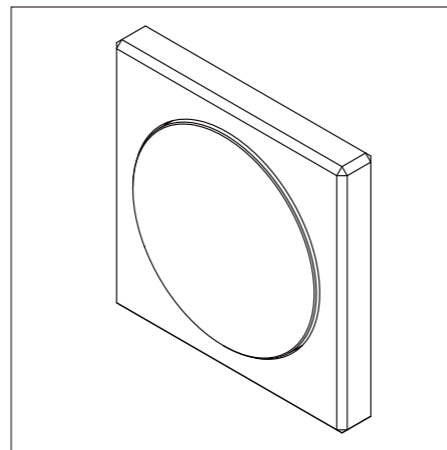

White Tile

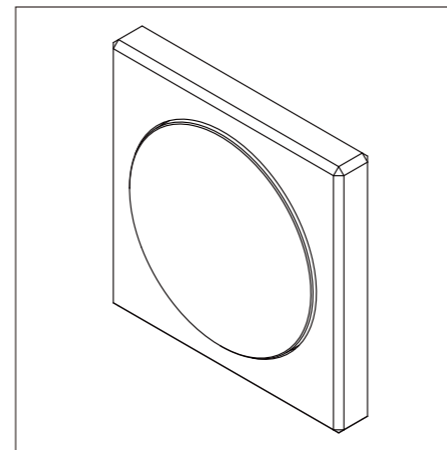

Green Tile

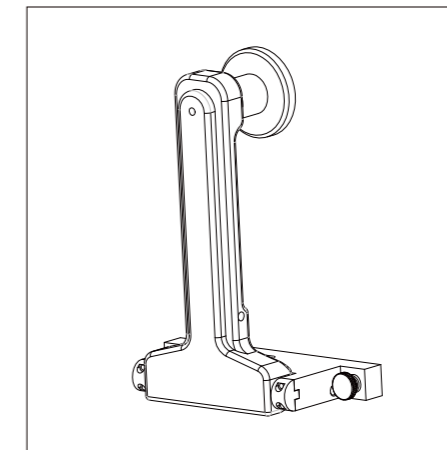

Sample Fixture

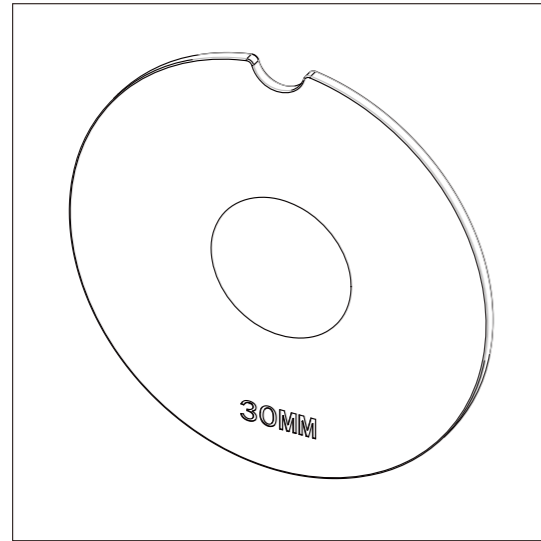

30mm Aperture

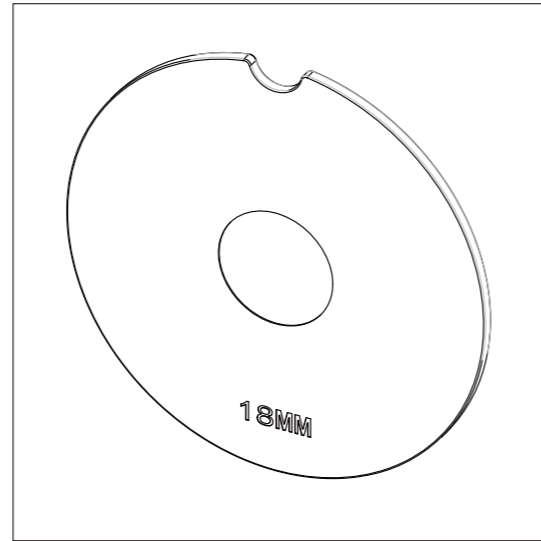

18 mm Aperture

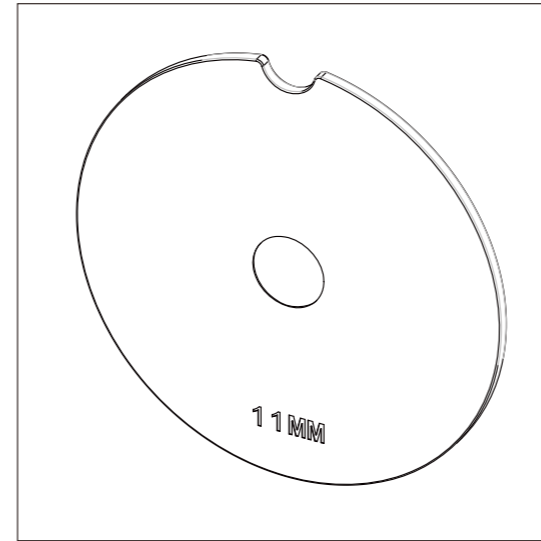

11 mm Aperture

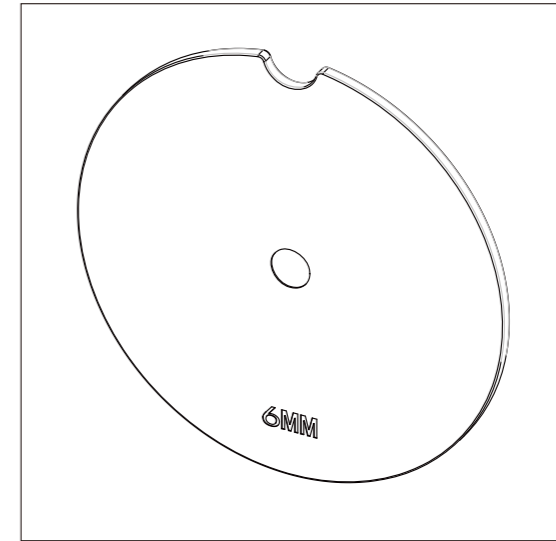

6 mm Aperture

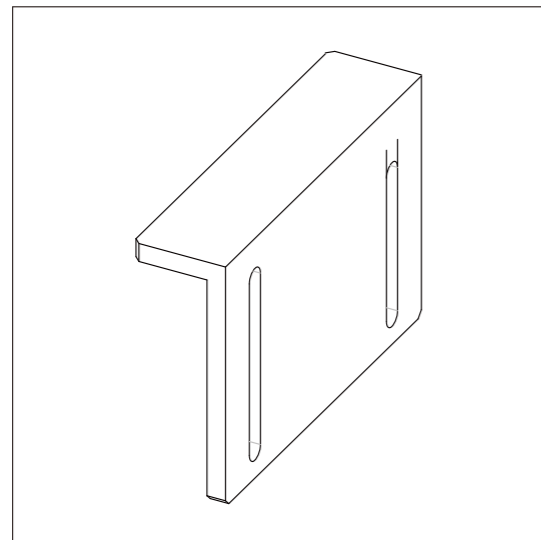

Support

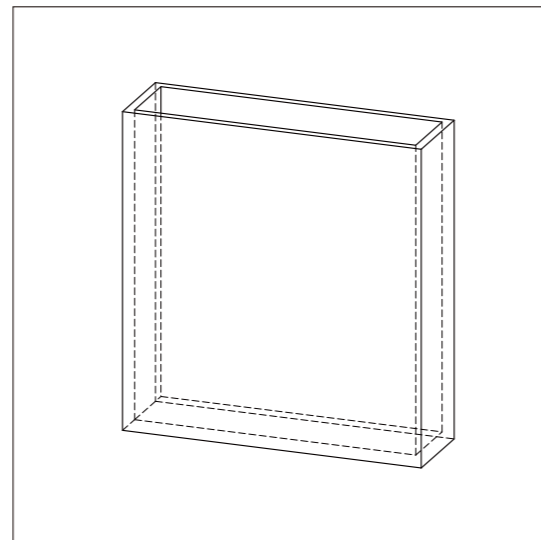

Glass Cell

## Optional Accessories

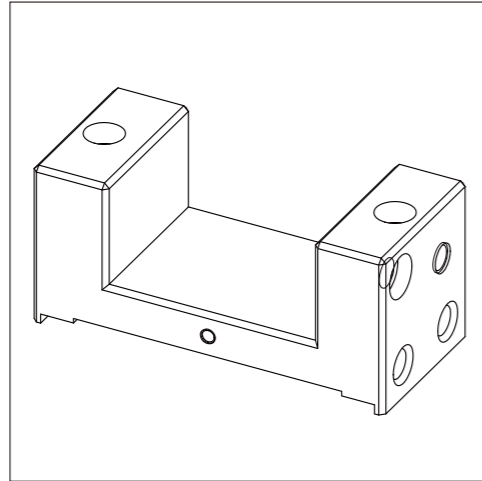

Transmittance Heating  
Fixture  
(including control circuit)

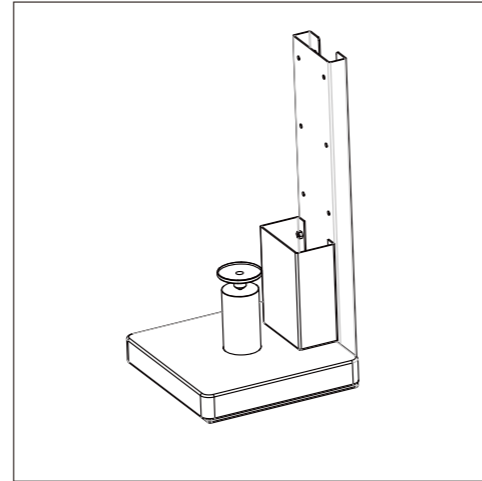

Vertical Support

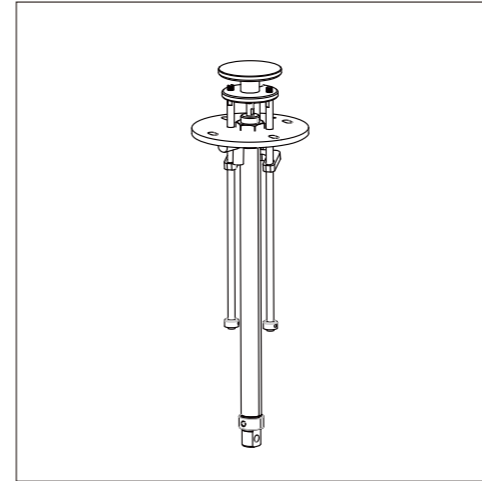

Pneumatic ram  
(including control circuit)

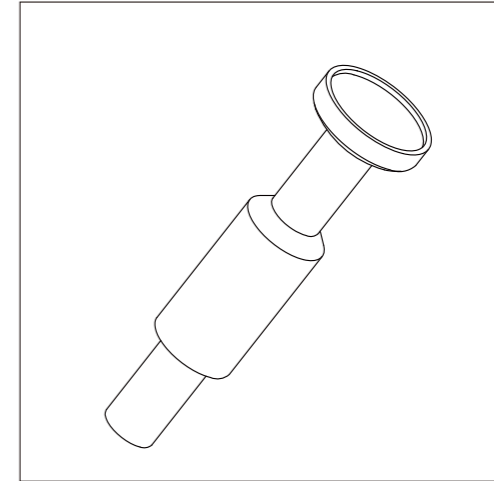

Small Sample  
Fixture

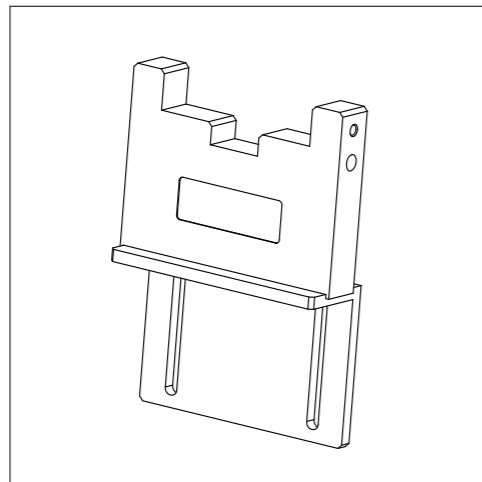

Reflectance Glass  
Cell Support

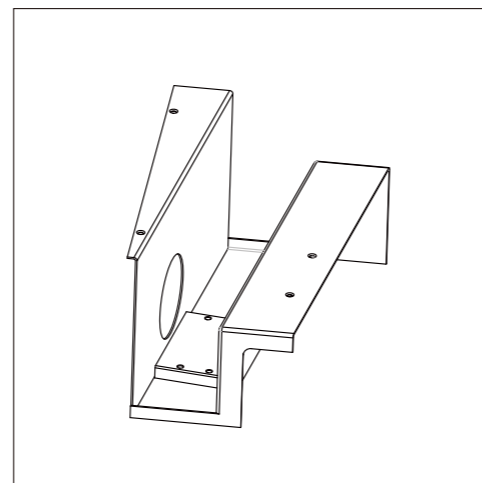

Corrosion Resistant  
Support  
(not removable)

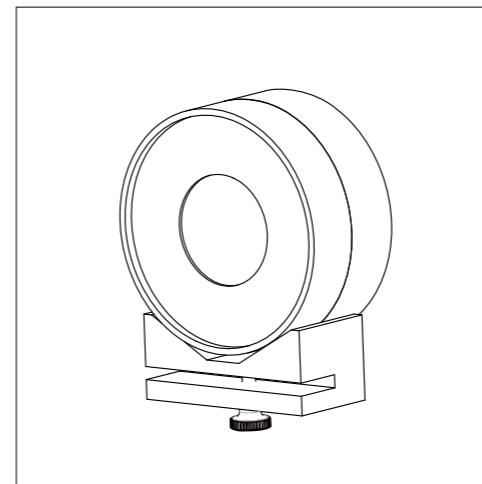

Fiber Holder

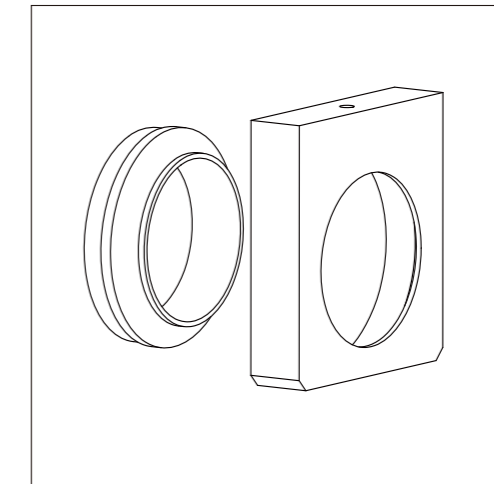

Film Fixture

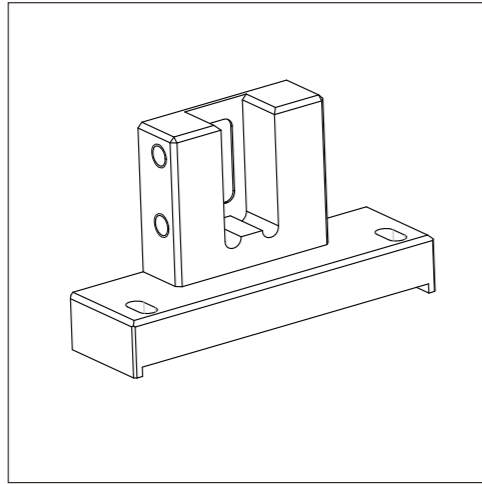

Transmittance Fixture  
for Small Aperture



Trolley Case

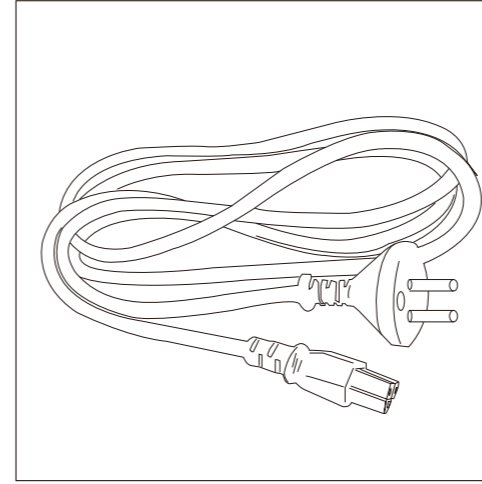

European  
Standard Plug

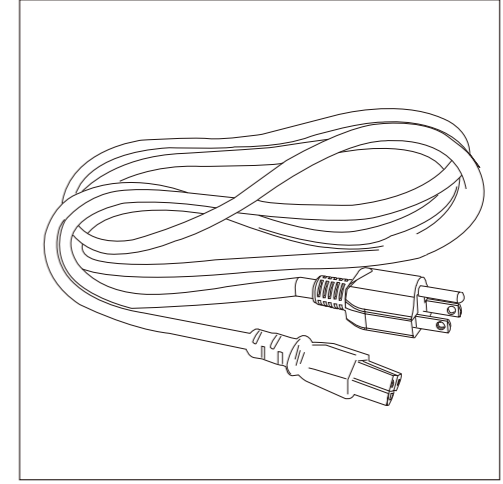

American  
Standard Plug

## Company Statement

1.The company promises that our spectrophotometer offers one year warranty from the purchase date. Non-artificial damage under normal use is subjected to free warranty. The company offers repair services for artificial damage, or damage after the warranty period ; however, the repair services would require fees relative to the damage.

2.Damage occurring under third party usage would not be eligible for warranty service.

3.The company is not responsible for data loss because of error, repairing, software upgrade,or power outages. To prevent loss of important data, please save copies of the data on your PC.

4.The copyright ownership of the instrument and its associated software belong to our company and is protected by the Copyright Laws of People's Republic of China.

5.Our company sells the instrument does not mean we transfer the copyright, or any intellectual property's ownership to the user.

6.The specifications and information in this manual are subjected to further updates without notice.